

L-BENT

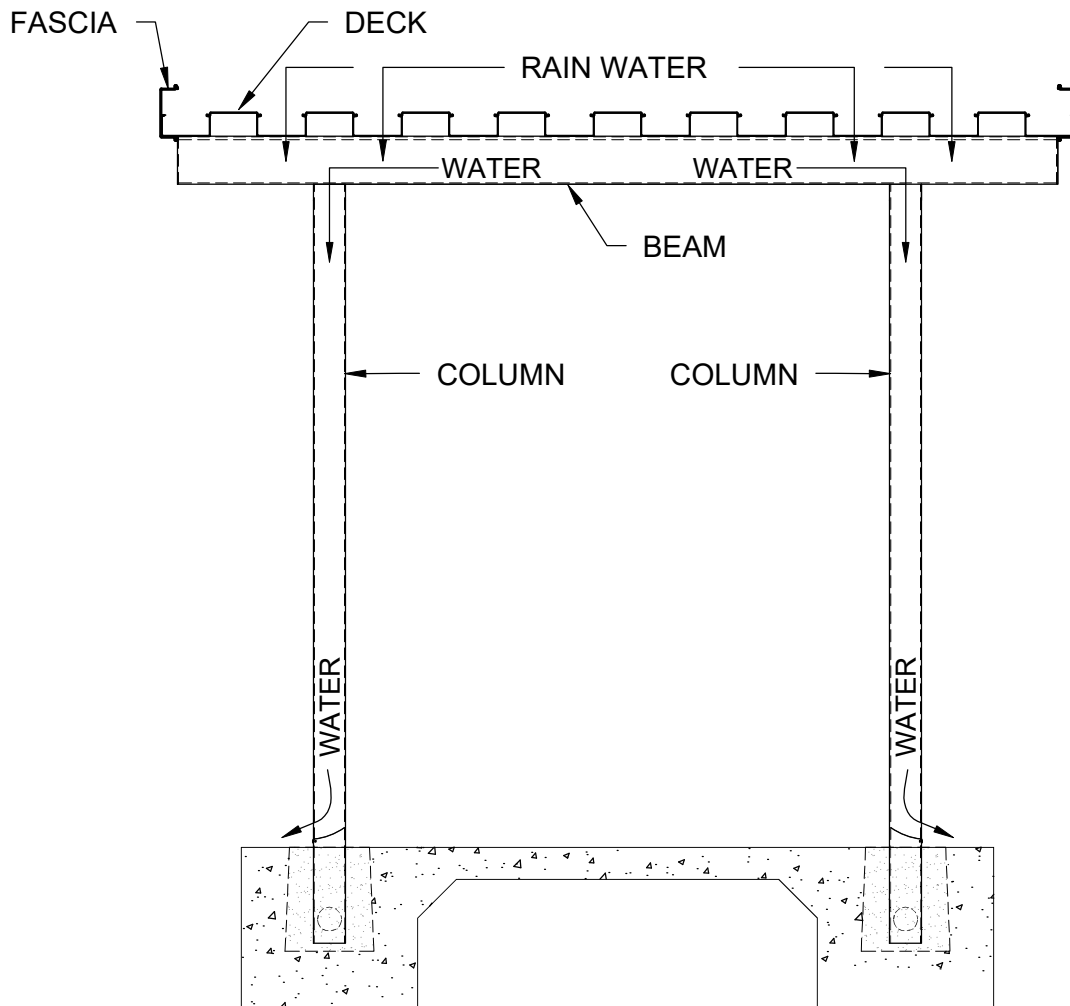

---

U-BENT

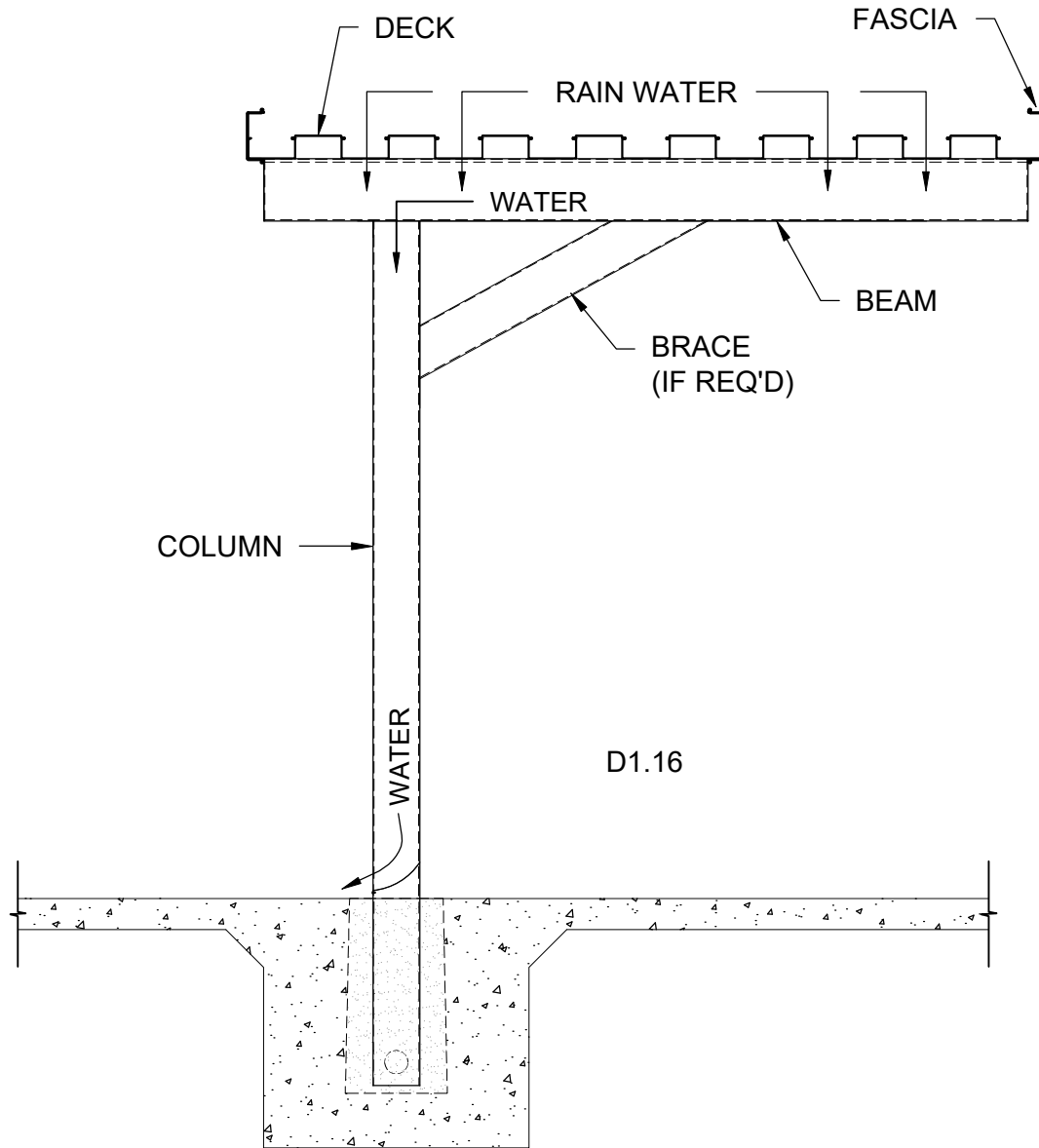

T-BRACE-BENT

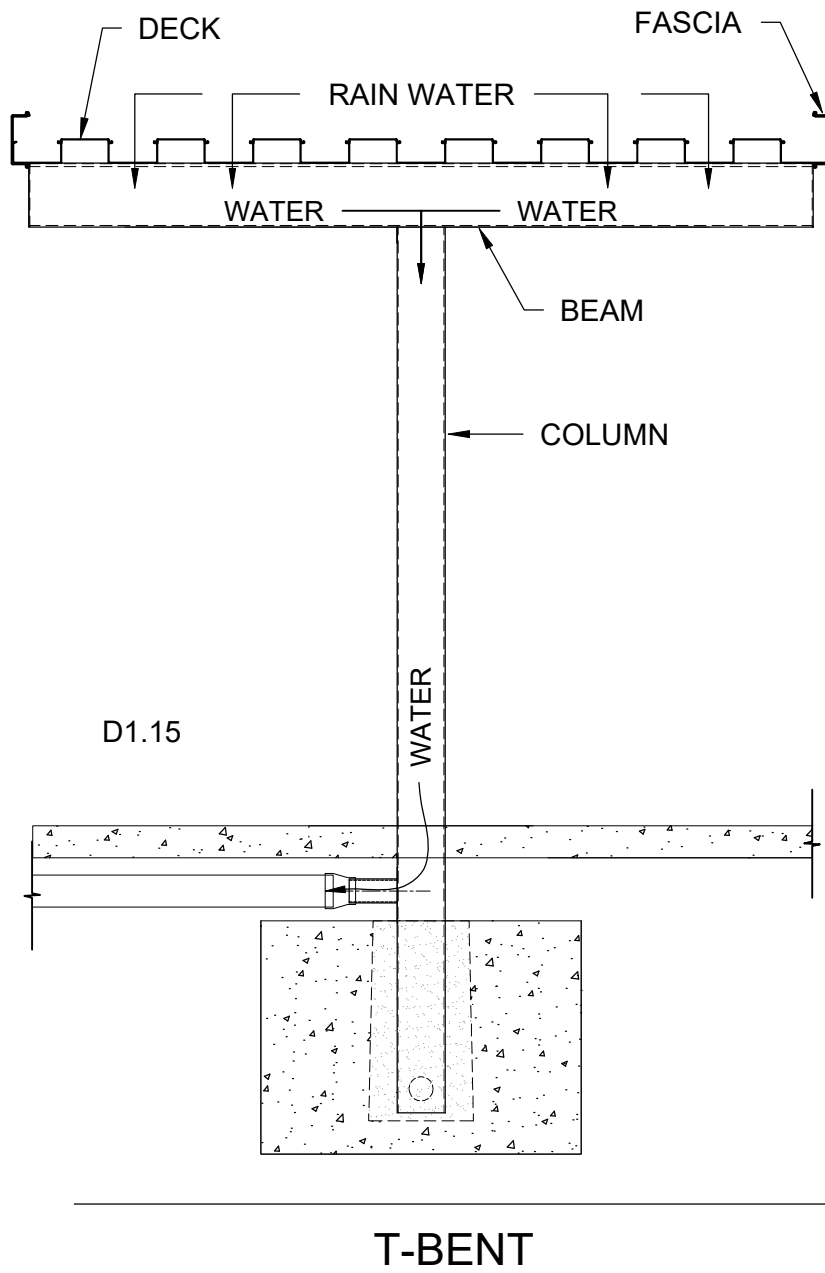

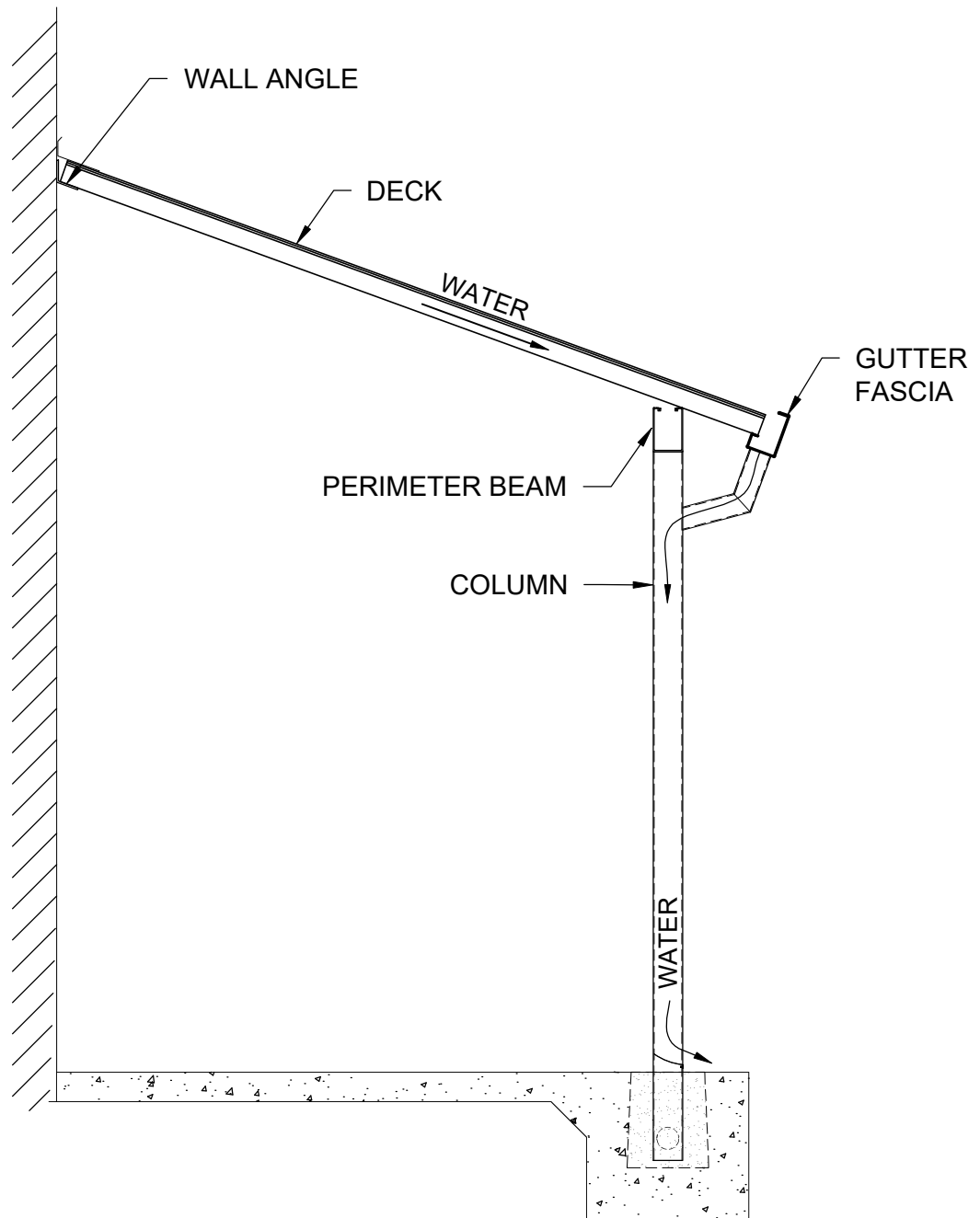

LEAN-TO-BENT

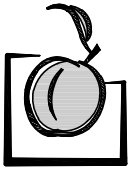

**Peachtree**  
PROTECTIVE COVERS

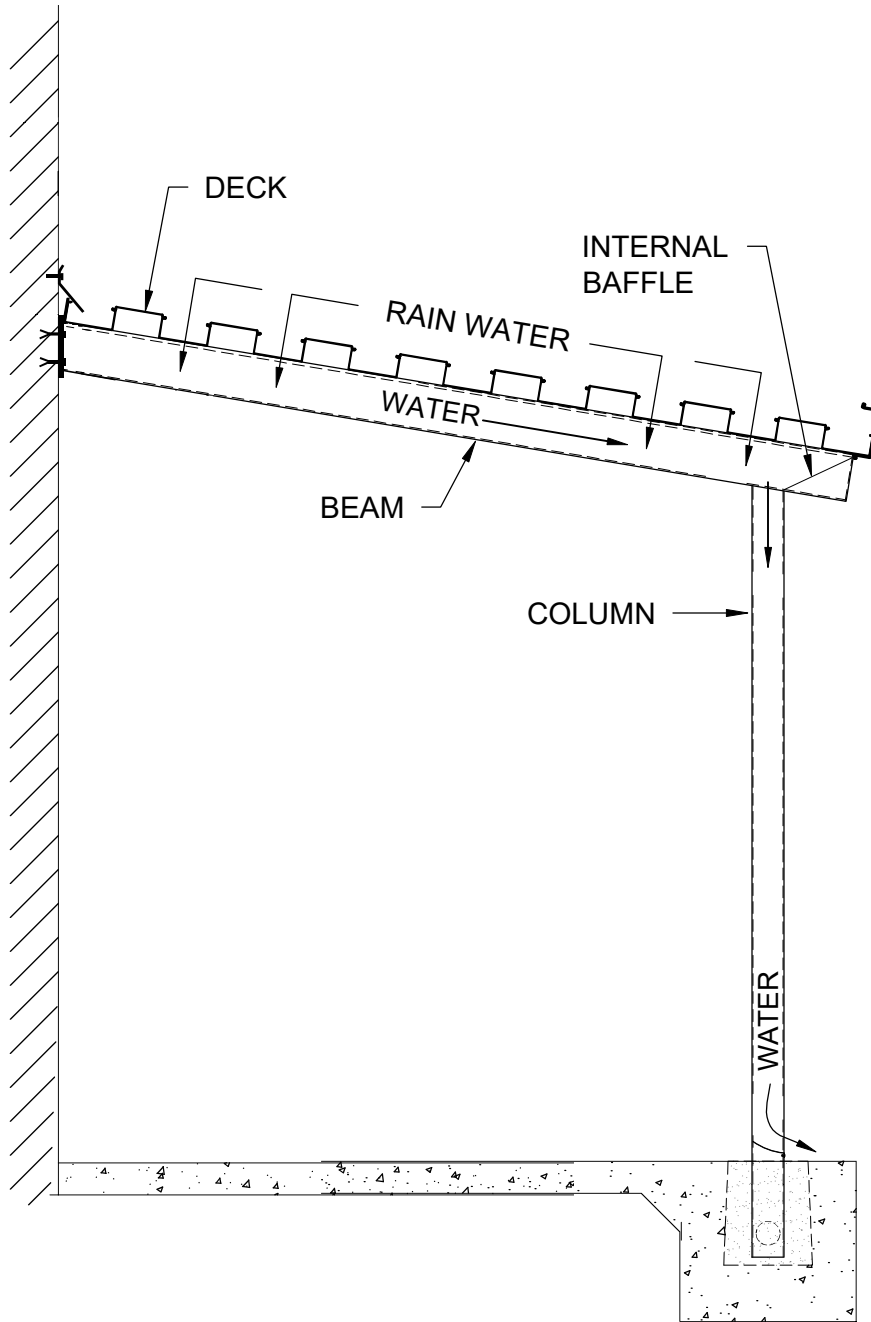

**SLOPED L-BENT**

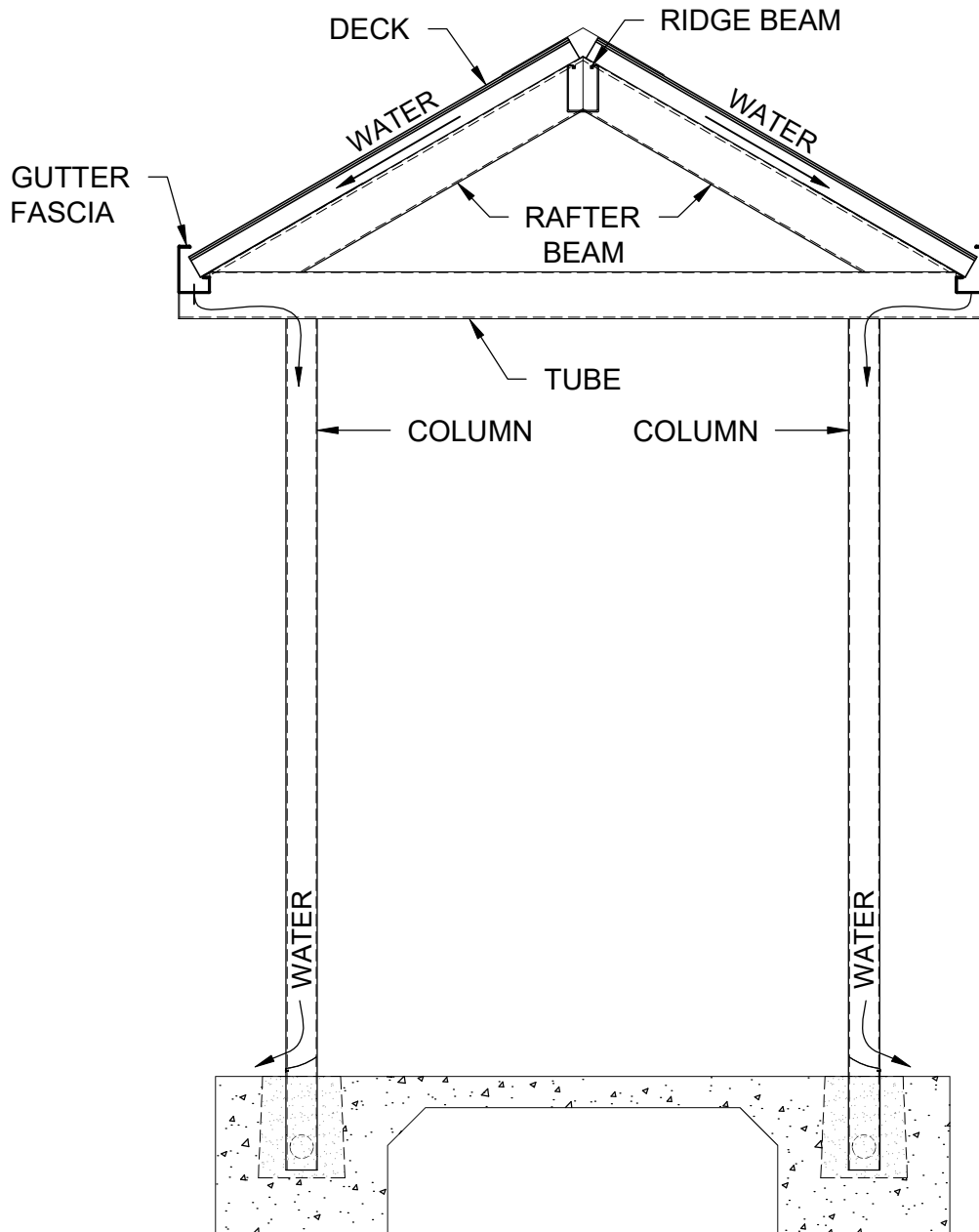

GABLE-BEAM-BENT

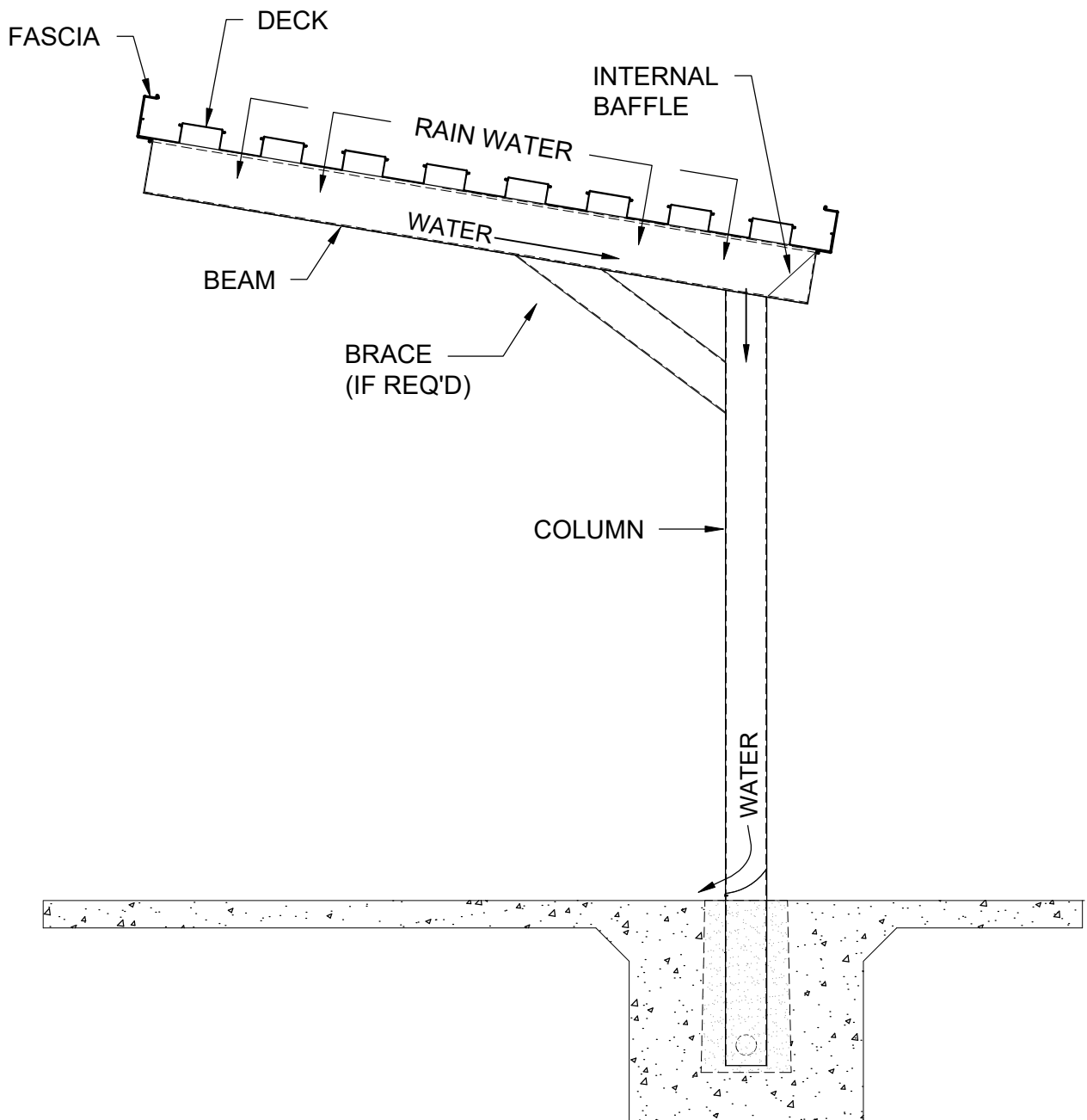

SLOPED CANTILEVERED BENT



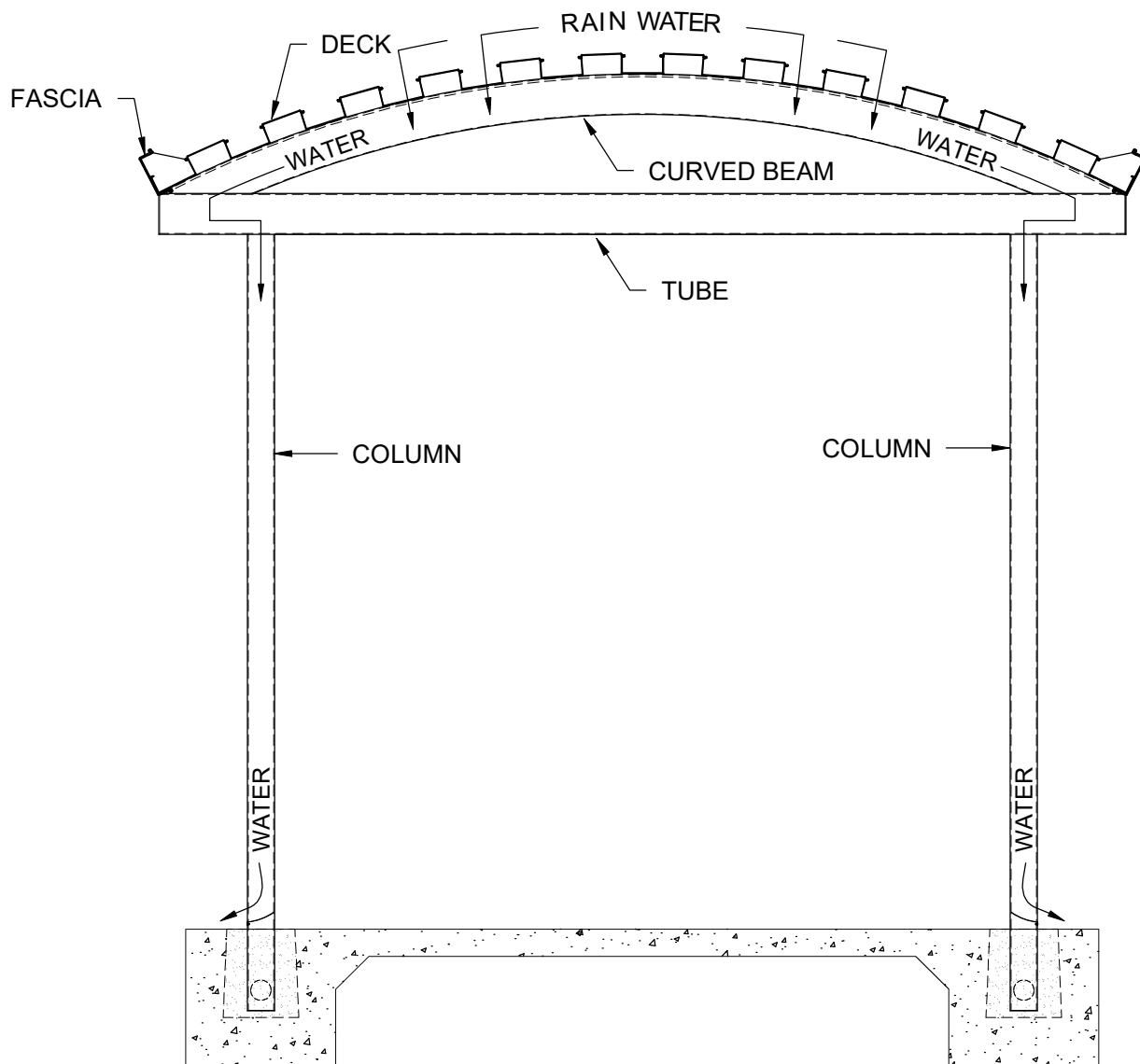

BARREL VAULT U-BENT

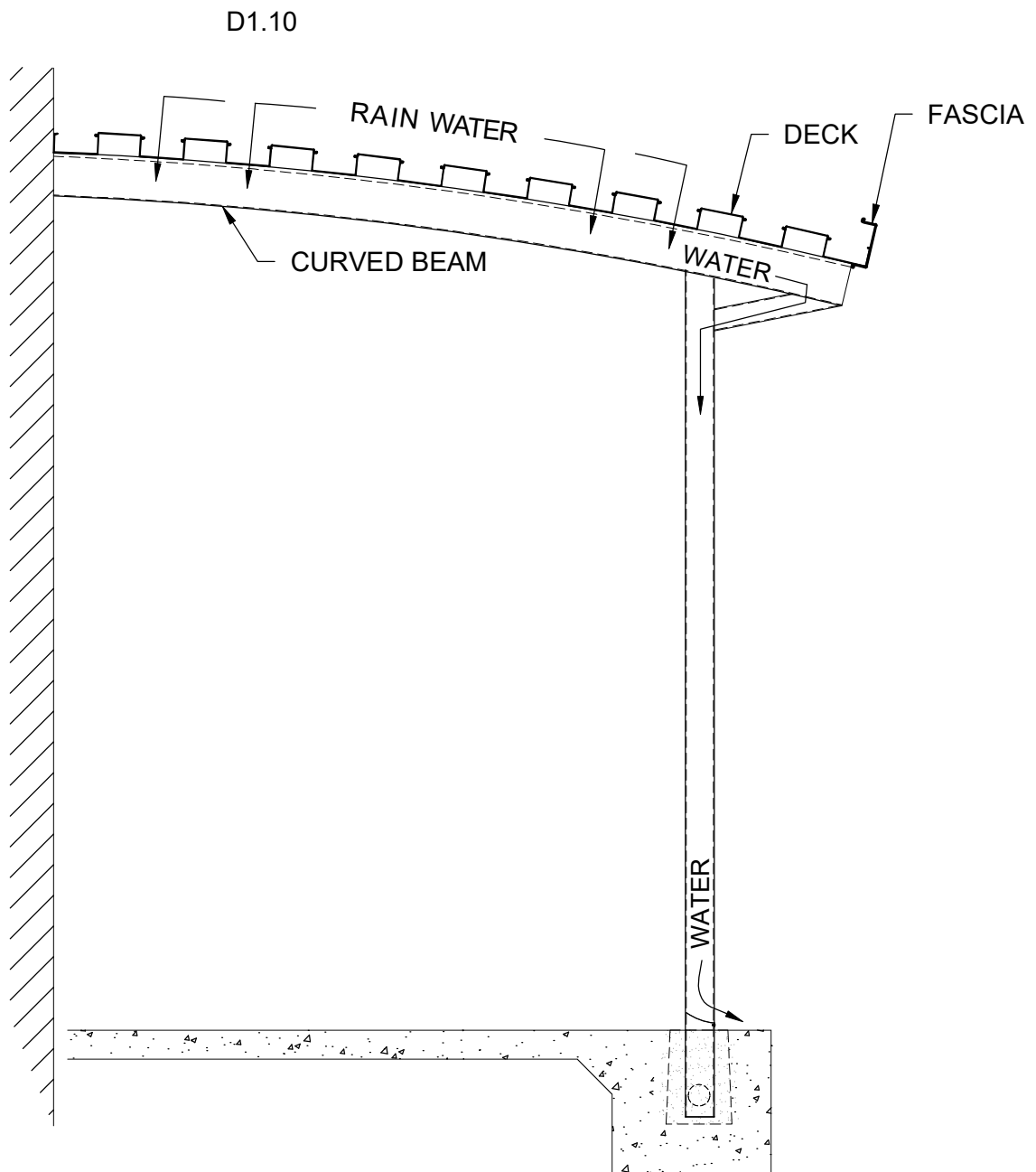

BARREL VAULT L-BENT

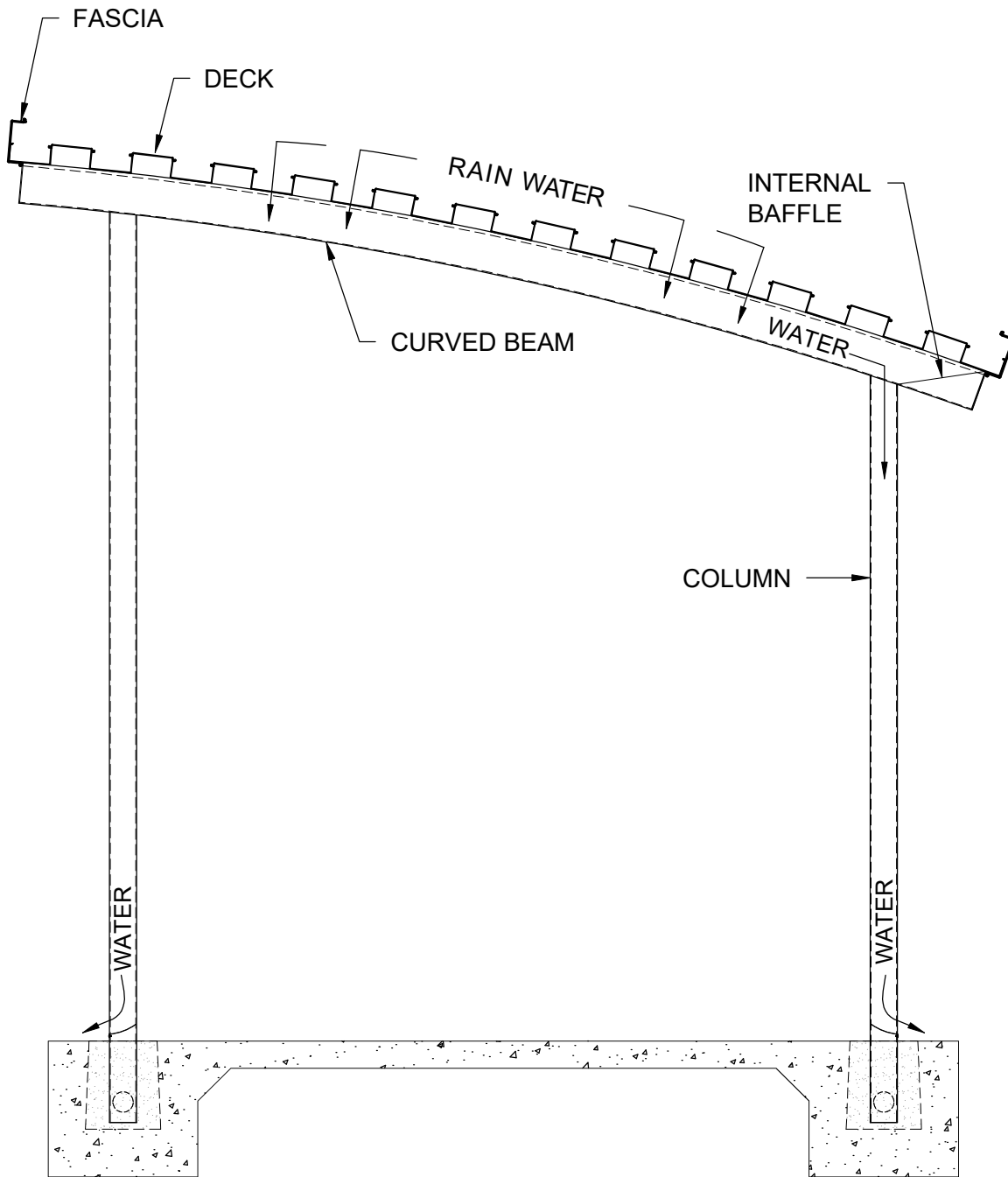

SLOPED BARREL VAULT U-BENT

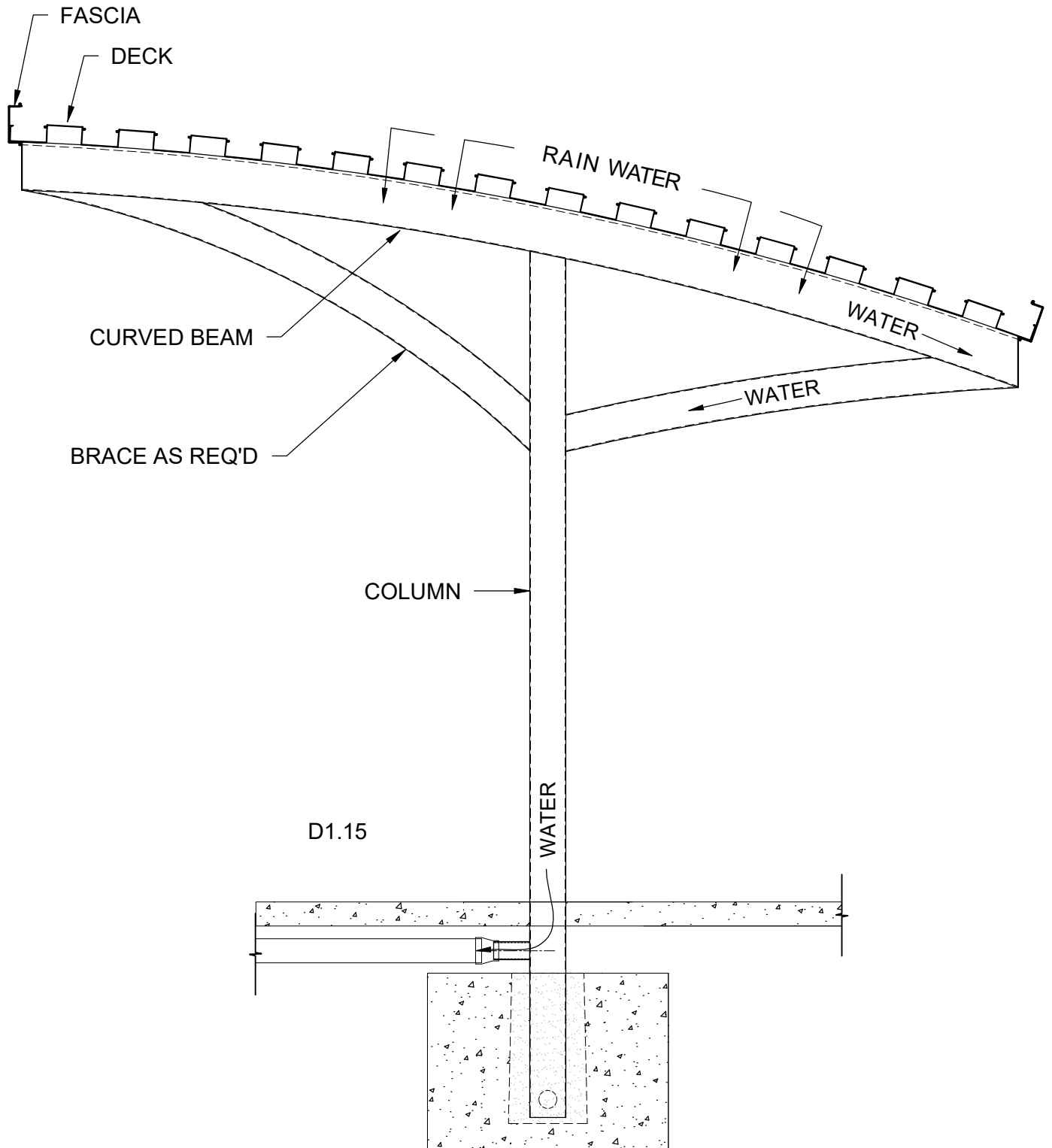

**SLOPED BARREL VAULT T-BENT**

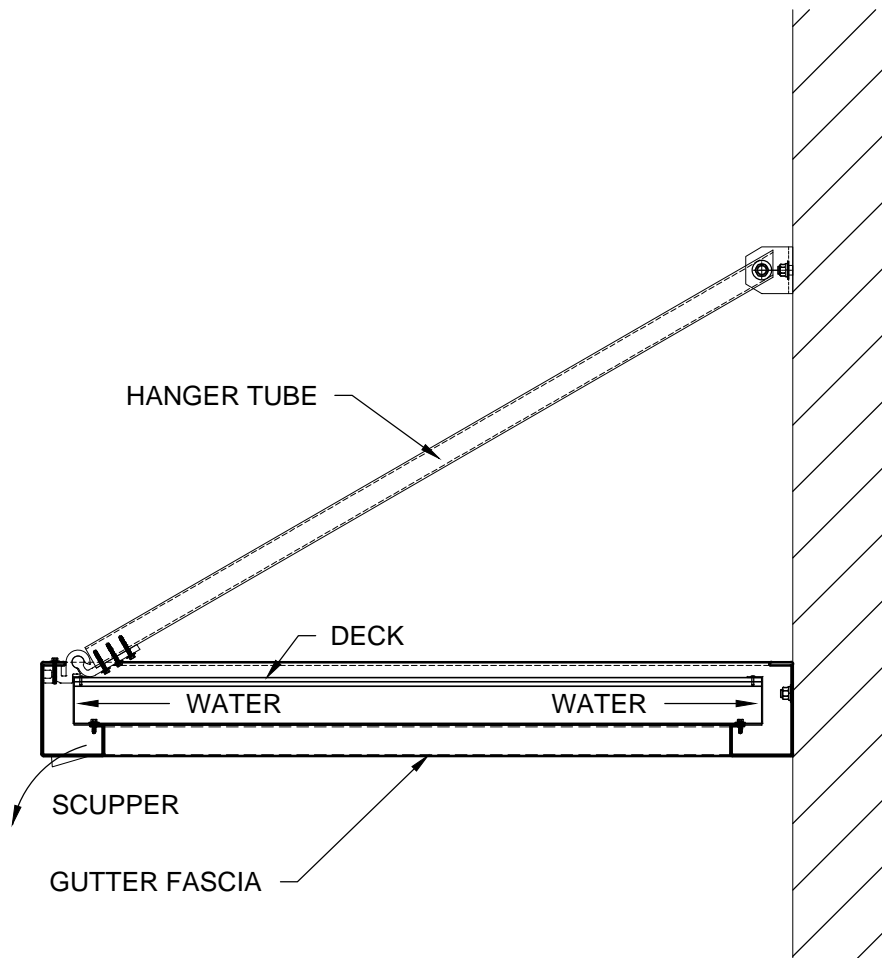

---

STANDARD HANGER CANOPY

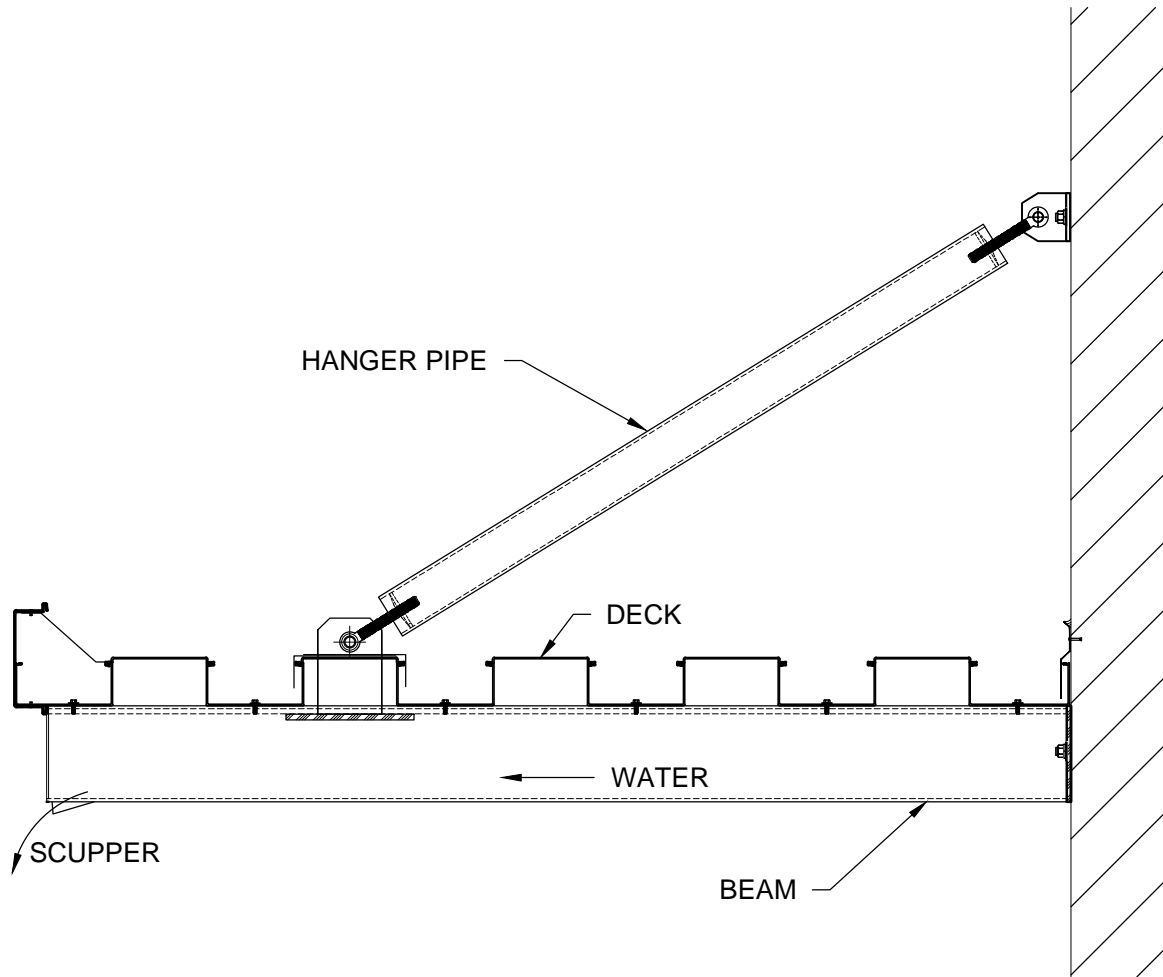

---

CUSTOM SUSPENDED CANOPY

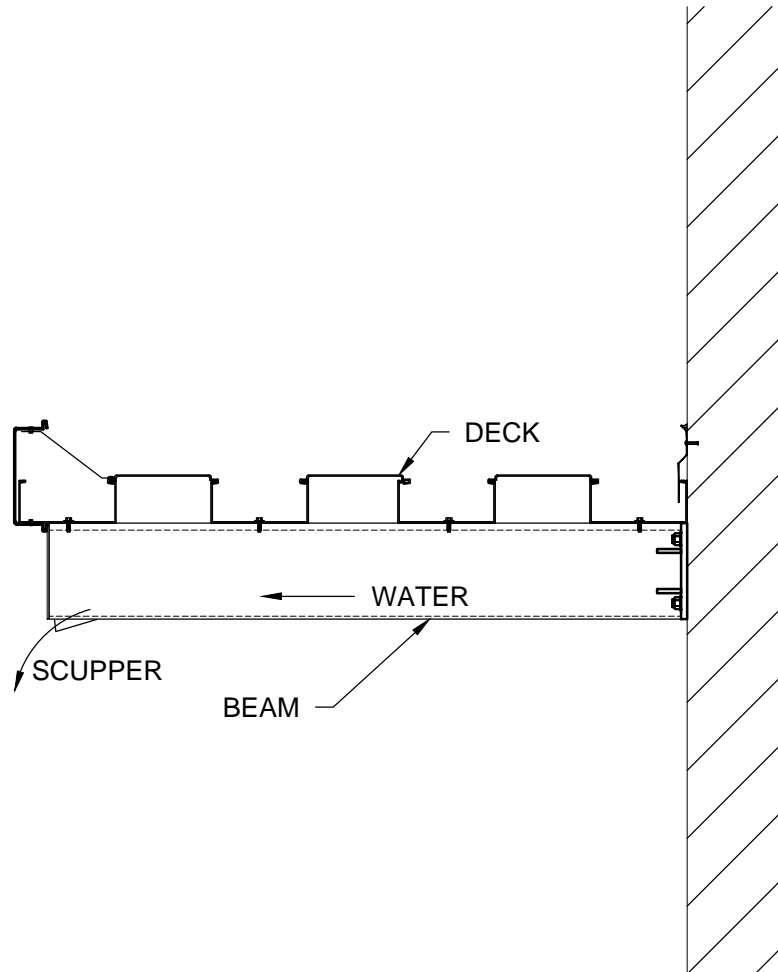

---

CUSTOM CANTILEVERED CANOPY

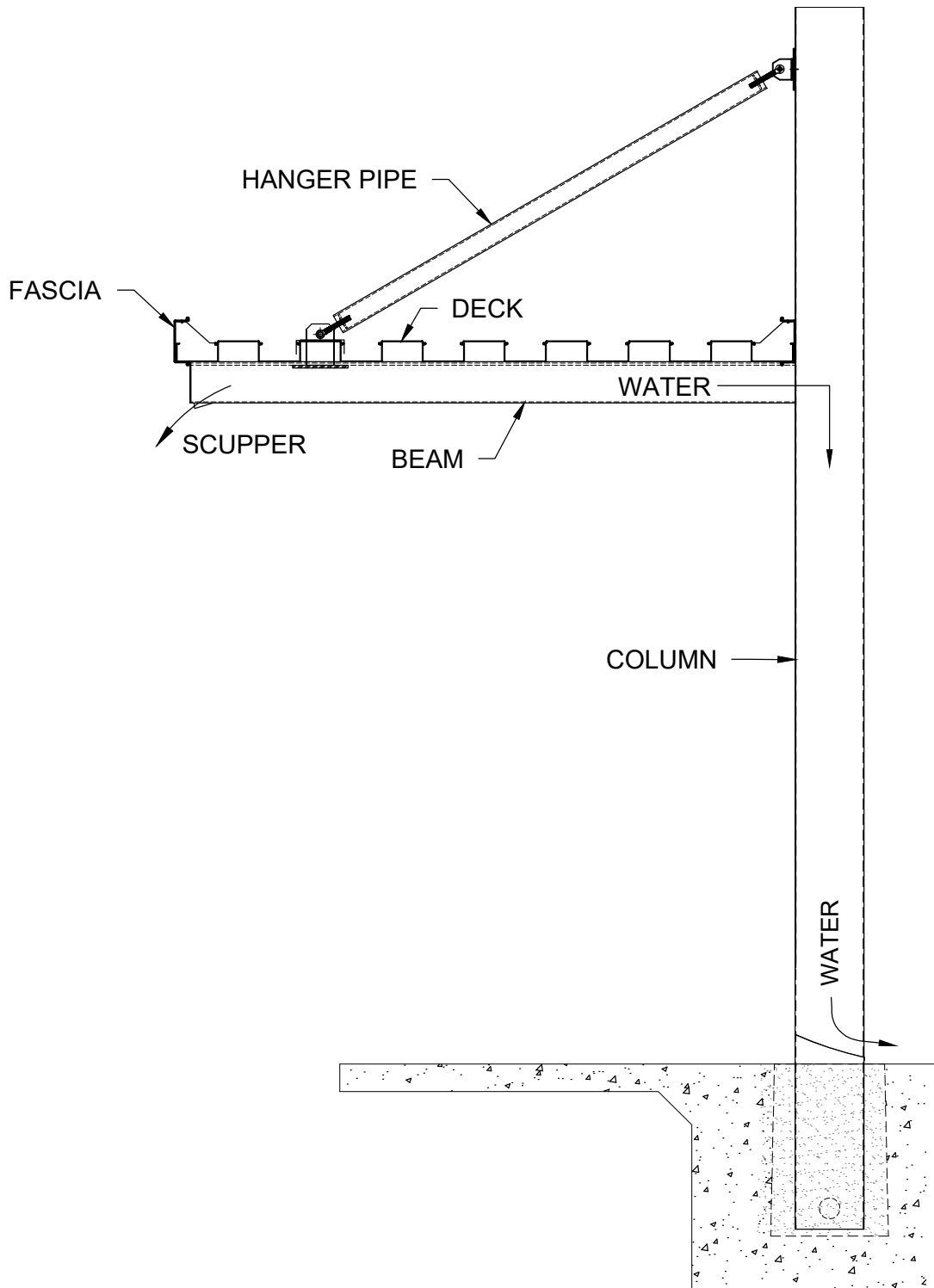

COLUMN SUPPORT CUSTOM SUSPENDED CANOPY



**FOOTING NOTE:**  
**PPC IS NOT RESPONSIBLE FOR FOOTING DESIGN**  
**THE ENGINEER OF RECORD (EOR) WILL NEED TO DESIGN/SIZE**  
**THE FOOTINGS TO RESIST THE LOADS PER APPROVED SHOP DRAWINGS**

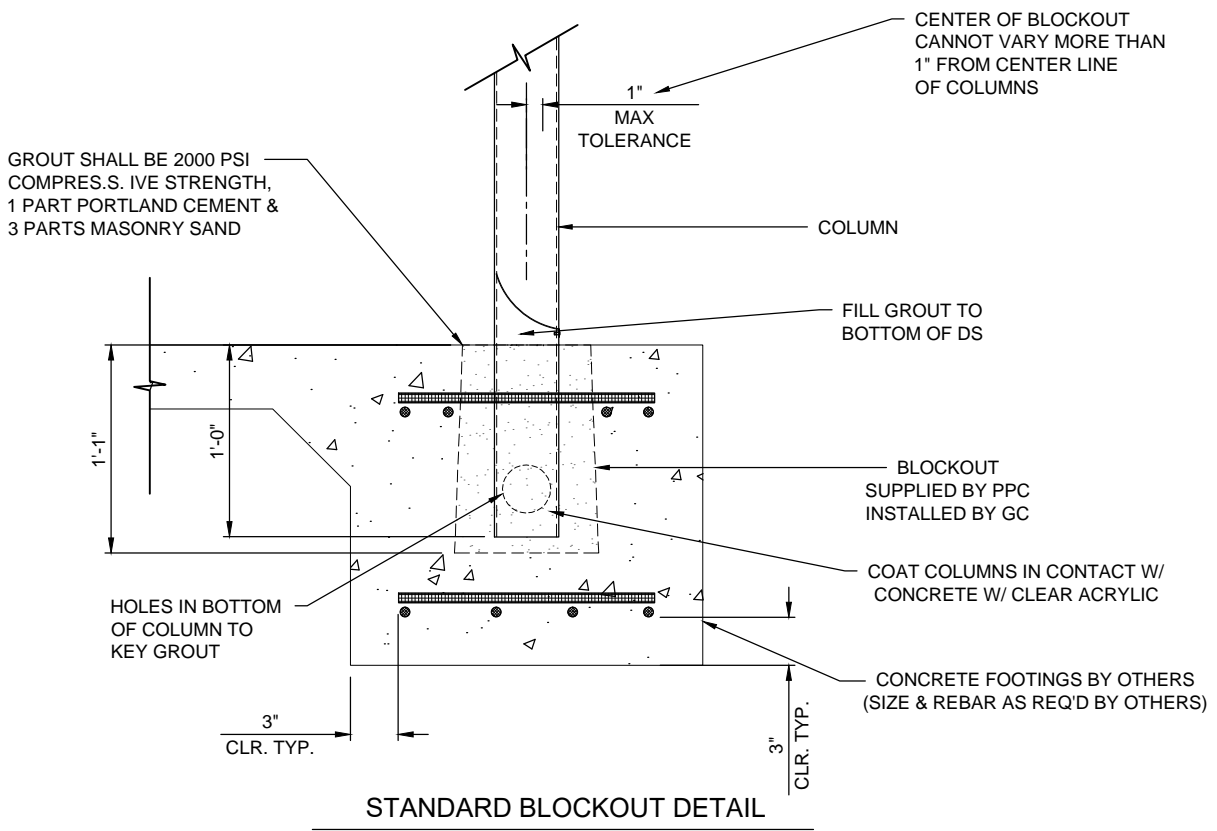



**FOOTING NOTE:**  
**PPC IS NOT RESPONSIBLE FOR FOOTING DESIGN**  
**THE ENGINEER OF RECORD (EOR) WILL NEED TO DESIGN/SIZE**  
**THE FOOTINGS TO RESIST THE LOADS PER APPROVED SHOP DRAWINGS**

