

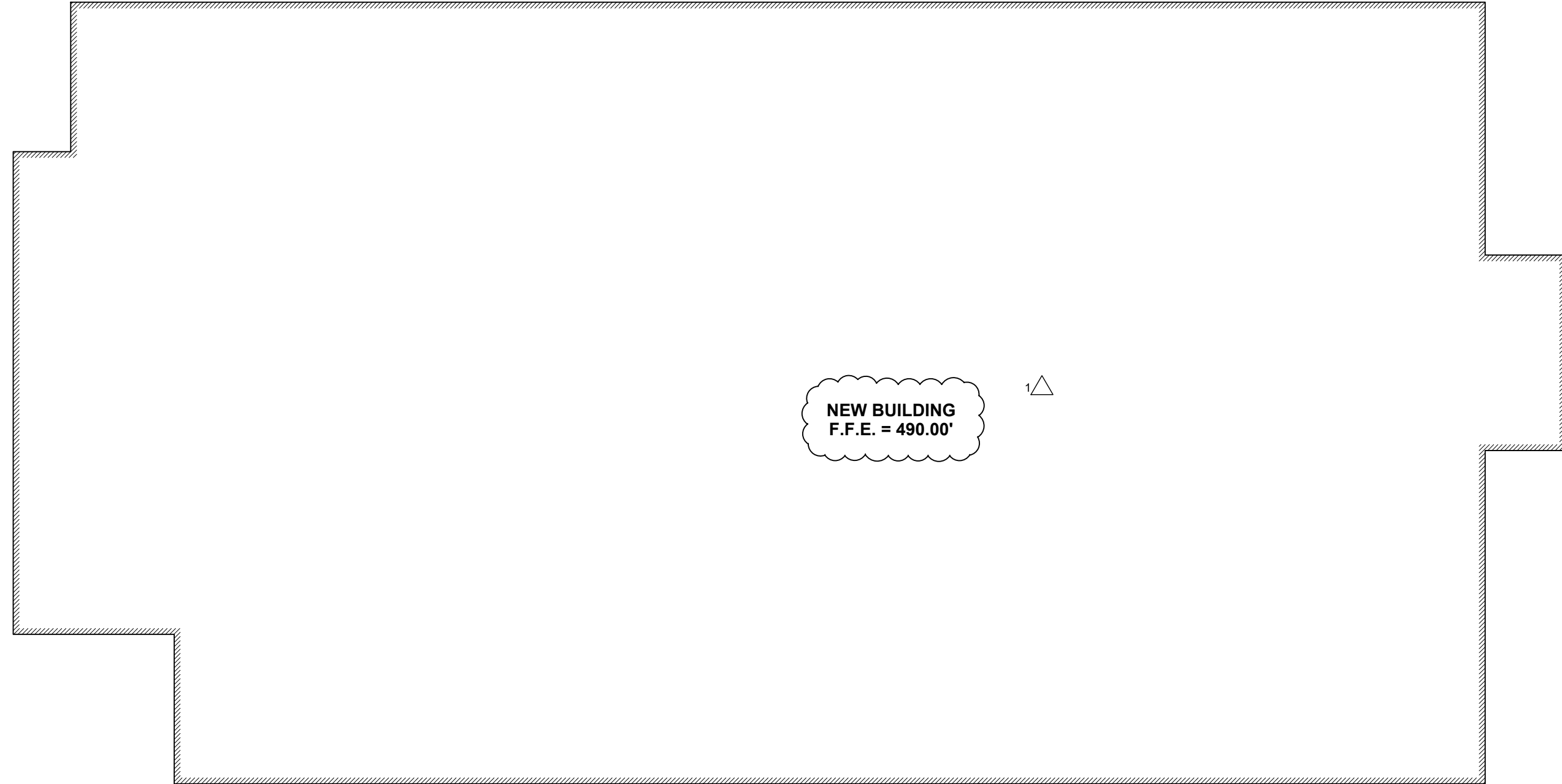



REV:	1	DATE:	3/4/16	SUBJECT:	INITIAL FILE & FIELD DWGS	DWG. BY:	LKA
------	---	-------	--------	----------	---------------------------	----------	-----

PROJECT:	GRACE COMMUNITY CHURCH
CUSTOMER:	BELL & ASSOCIATES CONSTRUCTION, LP
ARCHITECT:	RUFUS JOHNSON ASSOCIATES OF CLARKSVILLE, INC.
LOCATION:	CLARKSVILLE, TN
DATE:	11/6/15
DWN. BY:	LKA
CHKD. BY:	RW
DRAWING NO.:	1.00
PPC JOB NO.:	6319



1.70 | HC | CANOPY C

1.01 | CP | CANOPY A  
1.01 | DP

1.01 | CP | CANOPY B  
1.01 | DP

1 KEY PLAN  
1.00 SCALE: NTS CANOPIES: A, B & C  
REF.: 1/A.1





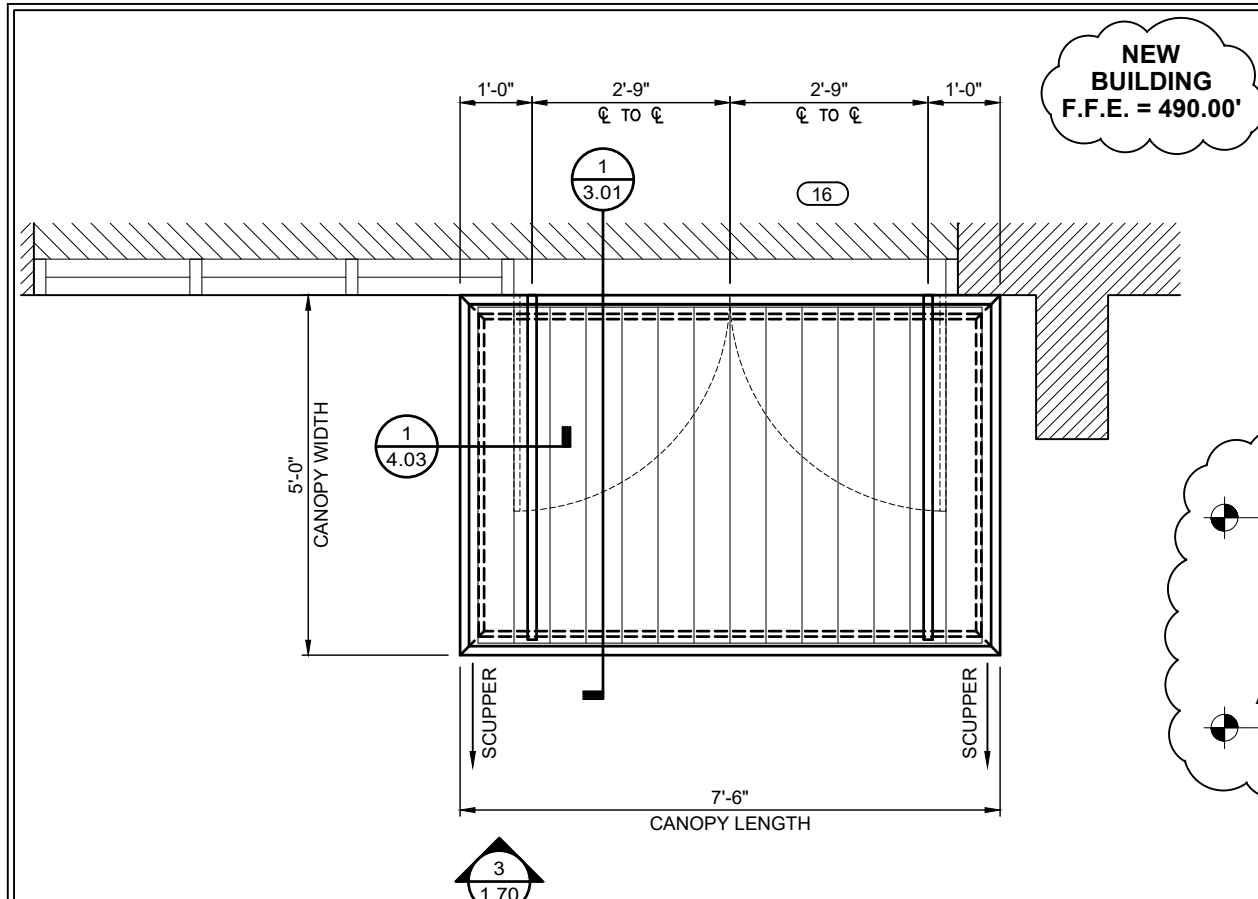

**1 DECK PLAN**  
 SCALE: 3/8"=1'-0" CANOPY:C  
 REF.: 1/A1.0 & A9.0

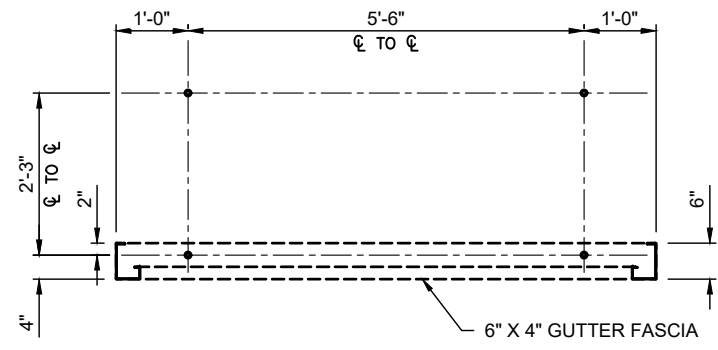
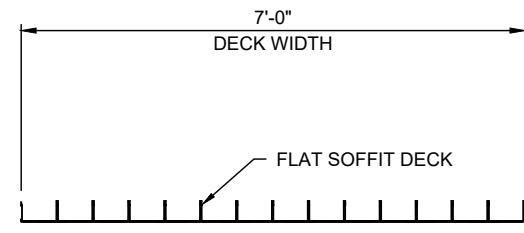

**2 BOLT SETTING PLAN**  
 SCALE: 3/8"=1'-0" CANOPY:C  
 REF.: C/A3.0

**NEW BUILDING**  
**F.F.E. = 490.00'**

(12'-0" A.F.F.)  
**FIELD VERIFY**  
 EL. 502.00'  
 TOP OF MASONRY

(9'-1" A.F.F.)  
**ARCHITECT VERIFY**  
 EL. 499.08'  
 BOT. OF FASCIA

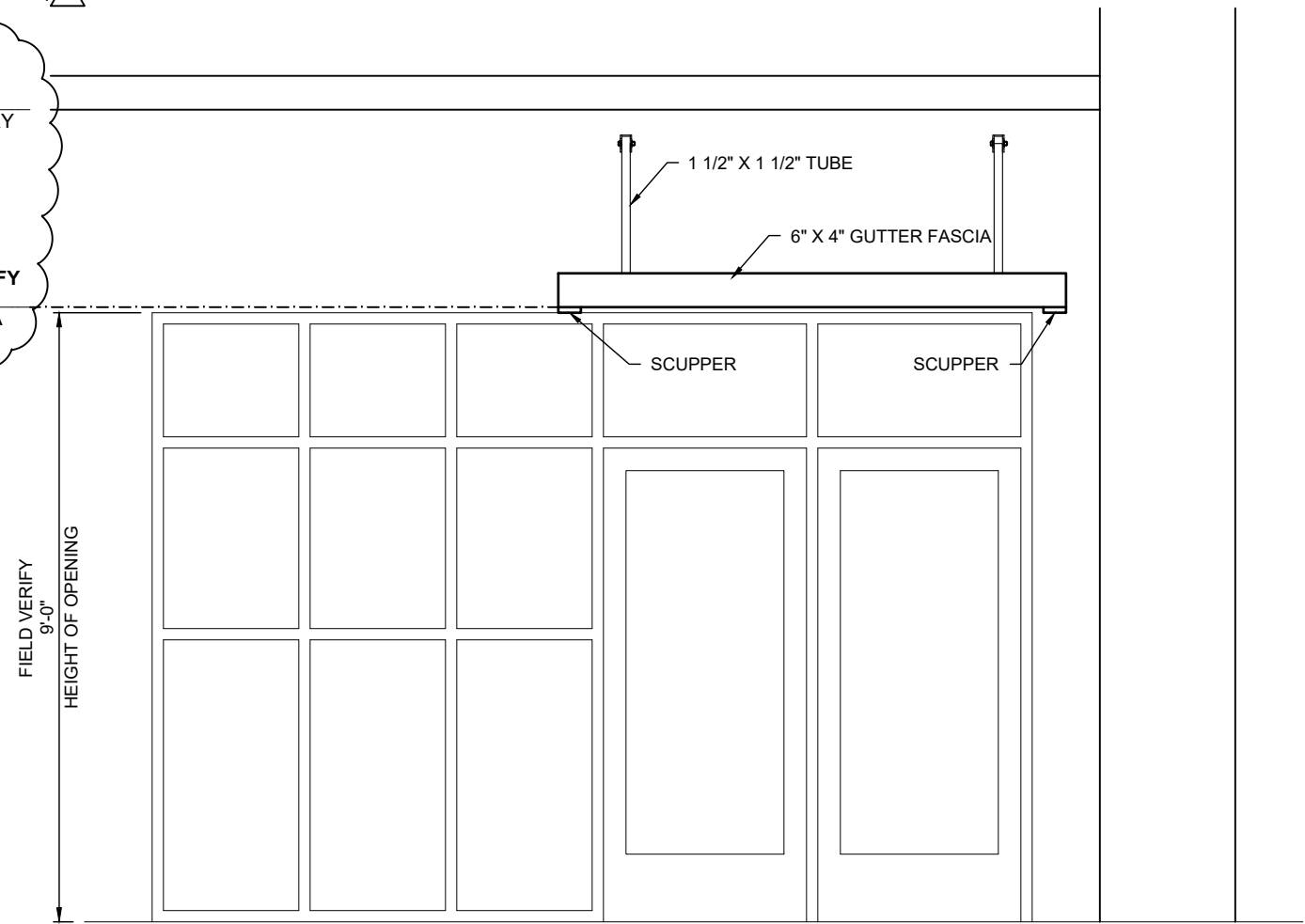

**3 ELEVATION**  
 SCALE: 3/8"=1'-0" CANOPY:C  
 REF.: 2/A3.0



DWG. BY	LKA
SUBJECT	INITIAL FILE & FIELD DWGS
DATE	3/4/16
REV.	1

PROJECT:	GRACE COMMUNITY CHURCH
CUSTOMER:	BELL & ASSOCIATES CONSTRUCTION, LP
ARCHITECT:	RUFUS JOHNSON ASSOCIATES OF CLARKSVILLE, INC.
LOCATION:	CLARKSVILLE, TN
DATE:	11/6/15
DWN. BY:	LKA
CHKD. BY:	RW
DRAWING NO.:	1.70
PPC JOB NO.:	6319

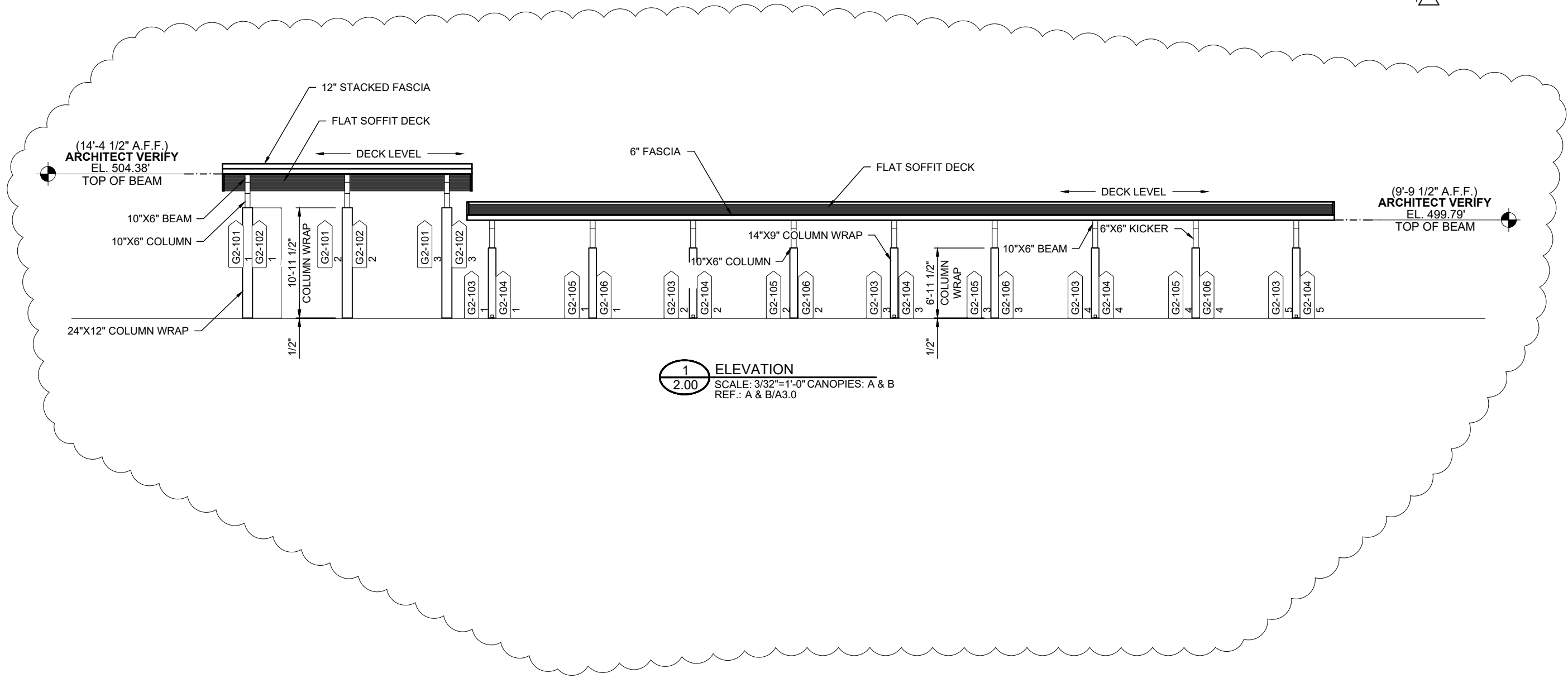

1 ELEVATION  
2.00  
SCALE: 3/32"=1'-0" CANOPIES: A & B  
REF.: A & B/A3.0

DWG. BY	LKA
SUBJECT	INITIAL FILE & FIELD DWGS
DATE	3/4/16
REV.	1

PROJECT:	GRACE COMMUNITY CHURCH
CUSTOMER:	BELL & ASSOCIATES CONSTRUCTION, LP
ARCHITECT:	RUFUS JOHNSON ASSOCIATES OF CLARKSVILLE, INC.
LOCATION:	CLARKSVILLE, TN
DATE:	11/6/15
DWN. BY:	LKA
CHKD. BY:	RW
DRAWING NO.:	2.00
PPC JOB NO.:	6319



GC/ARCH NOTE:  
PPC NEEDS ACCESS INSIDE WALL  
TO MAKE BOLTED CONNECTION.

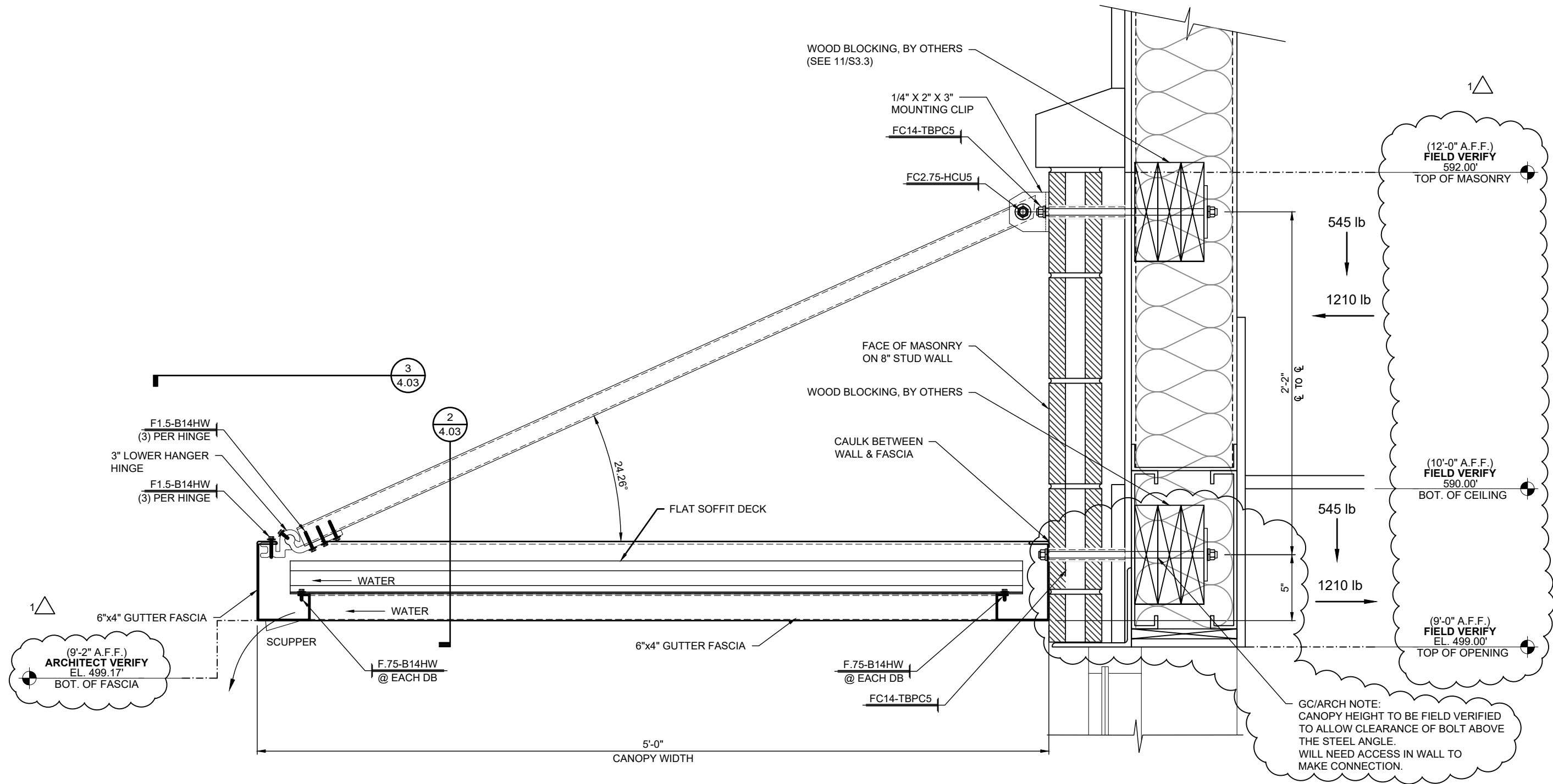

GC/ARCH NOTE:  
PROVIDE STRUCTURAL FRAMING/INFILL  
IN WALL AT CANOPY CONNECTION  
POINTS TO SUPPORT LOAD INDICATED.

INSTALLER NOTE:  
COORDINATE CANOPY LOCATION  
AND INSTALLATION WITH OWNER.

**1**  
3.01 CANOPY SECTION  
SCALE: 1 1/2"=1'-0" CANOPY: C  
REF.: 2 & A/A6.1, 8/A6.7 & 11/S3.3

DWG. BY	LKA
SUBJECT	INITIAL FILE & FIELD DWGS
DATE	3/4/16
REV.	1

PROJECT:	GRACE COMMUNITY CHURCH
CUSTOMER:	BELL & ASSOCIATES CONSTRUCTION, LP
ARCHITECT:	RUFUS JOHNSON ASSOCIATES OF CLARKSVILLE, INC.
LOCATION:	CLARKSVILLE, TN

DATE:	11/6/15
DWN. BY:	LKA
CHKD. BY:	RW
DRAWING NO.:	3.01
PPC JOB NO.:	6319

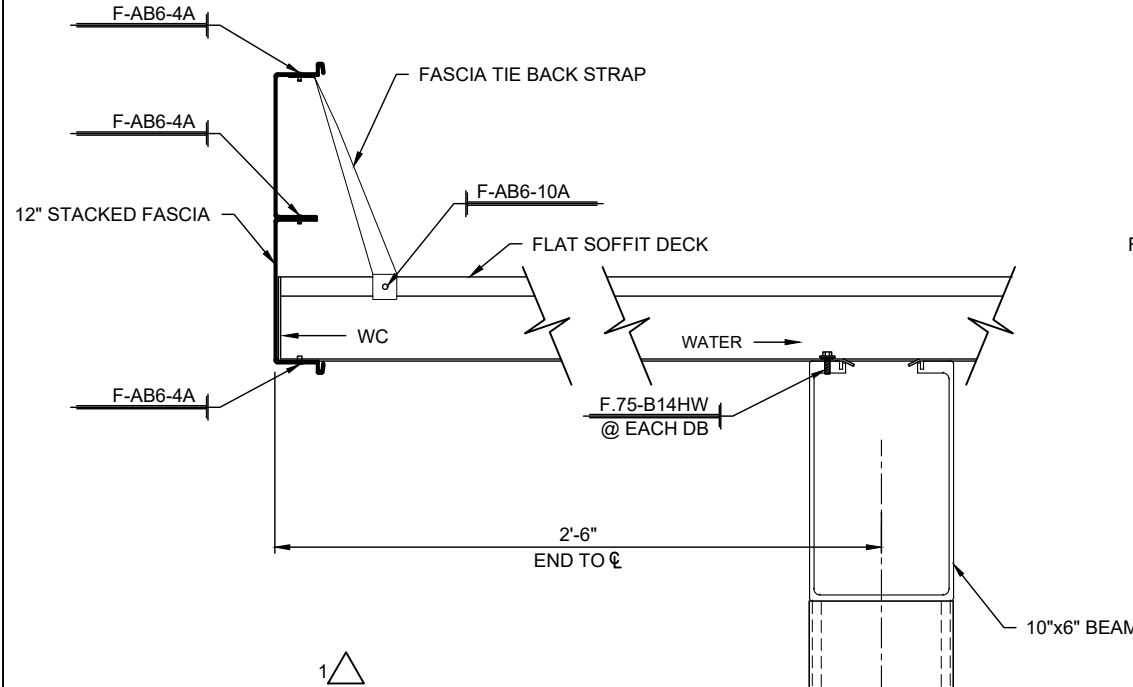

1

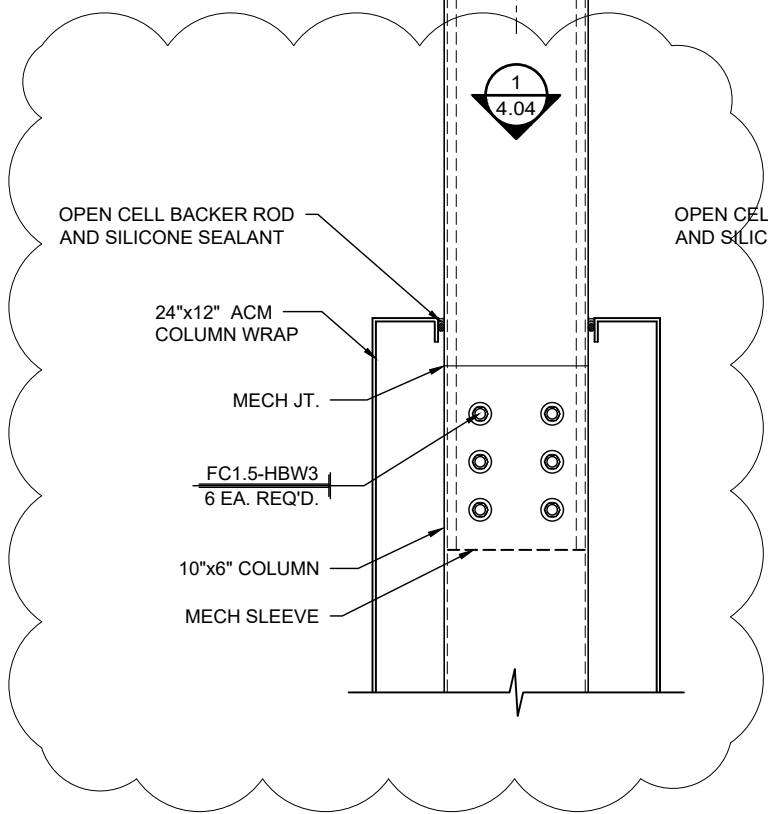

**1**  
4.00 CANOPY END DETAIL  
SCALE: 1 1/2"=1'-0" CANOPY:A  
REF.: NONE

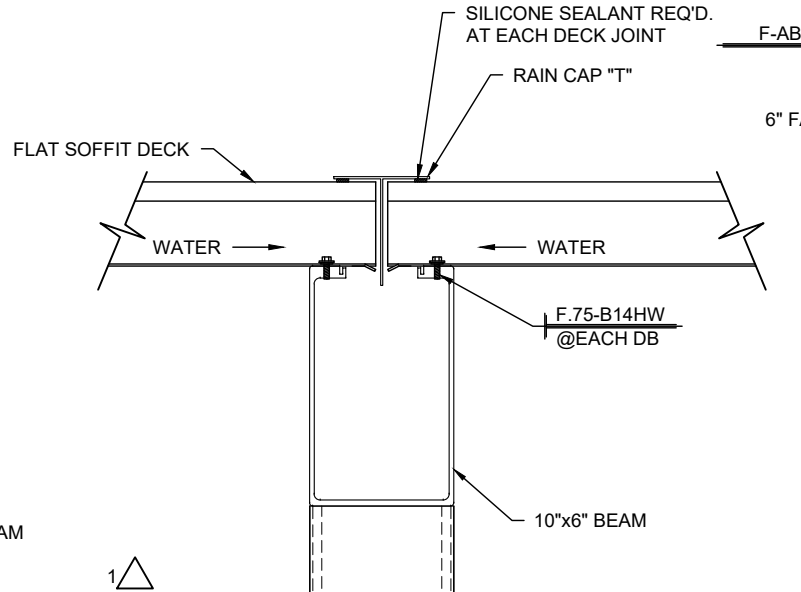

1

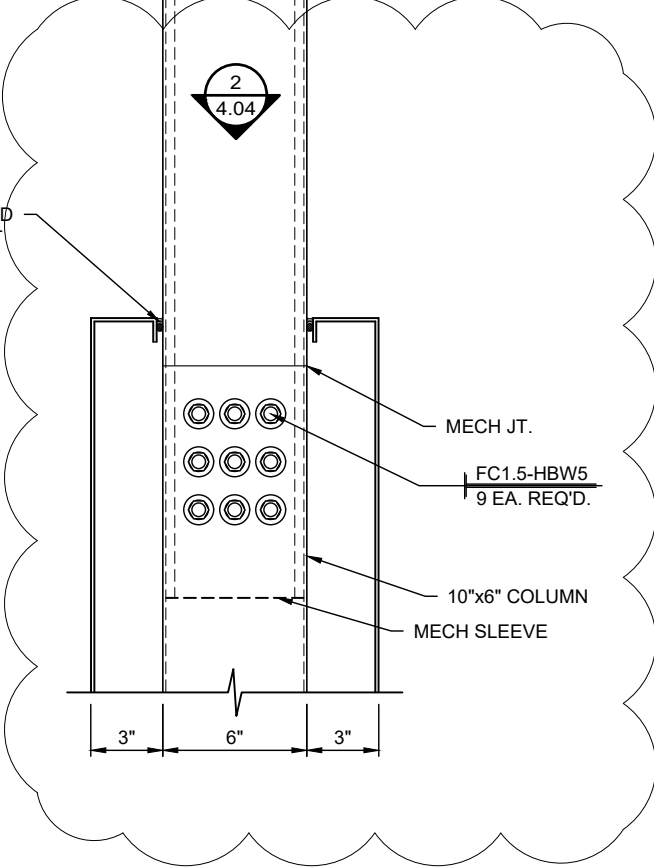

**2**  
4.00 CANOPY BAY BREAK DETAIL  
SCALE: 1 1/2"=1'-0" CANOPY:B  
REF.: 1/A6.7 (SIM)

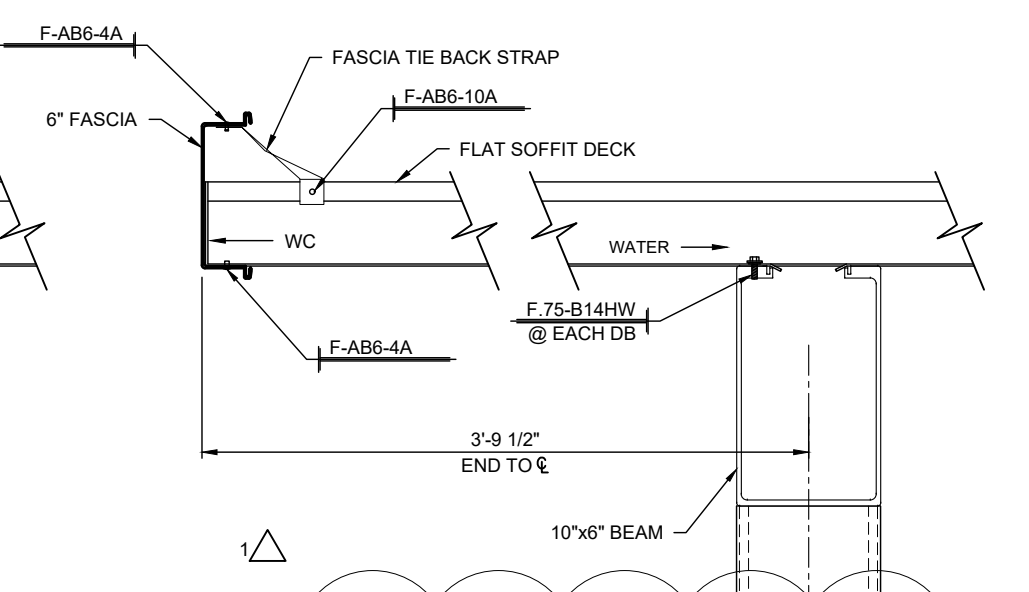

1

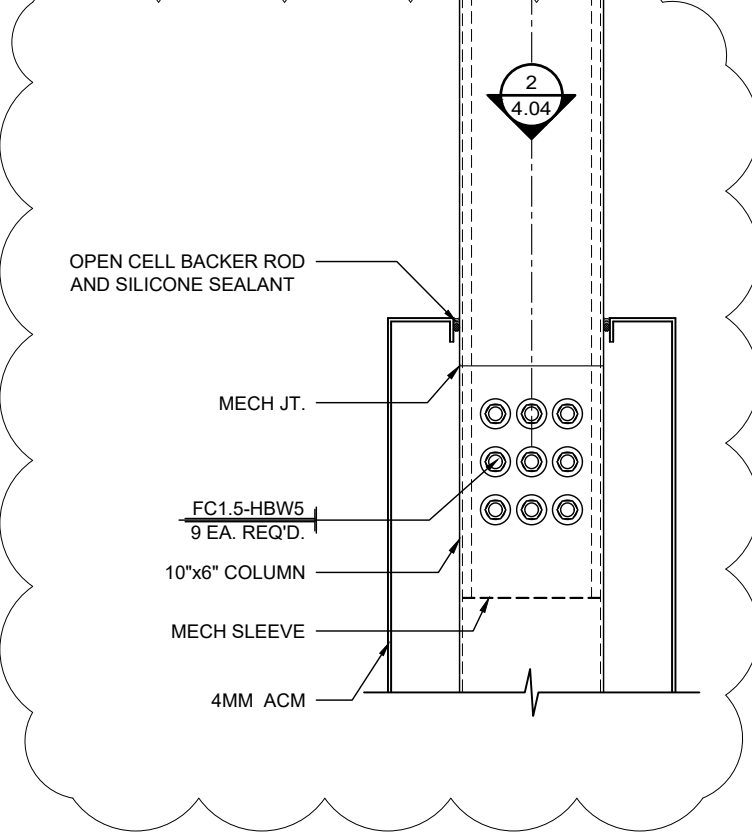

**3**  
4.00 CANOPY END DETAIL  
SCALE: 1 1/2"=1'-0" CANOPY:B  
REF.: NONE

DWG. BY	LKA
SUBJECT	INITIAL FILE & FIELD DWGS
DATE	3/4/16
REV.	1

PROJECT	GRACE COMMUNITY CHURCH
CUSTOMER	BELL & ASSOCIATES CONSTRUCTION, LP
ARCHITECT	RUFUS JOHNSON ASSOCIATES OF CLARKSVILLE, INC.
LOCATION	CLARKSVILLE, TN

DATE	11/6/15
DWN. BY	LKA
CHKD. BY	RW
DRAWING NO.	4.00
PPC JOB NO.	6319



DWG. BY	LKA
SUBJECT	INITIAL FILE & FIELD DWGS
DATE	3/4/16
REV.	1

PROJECT	GRACE COMMUNITY CHURCH
CUSTOMER	BELL & ASSOCIATES CONSTRUCTION, LP
ARCHITECT	RUFUS JOHNSON ASSOCIATES OF CLARKSVILLE, INC.
LOCATION	CLARKSVILLE, TN
DATE	11/6/15
DWN. BY	LKA
CHKD. BY	RW
DRAWING NO.	4.01
PPC JOB NO.	6319

MB= METAL BUILDING SUB

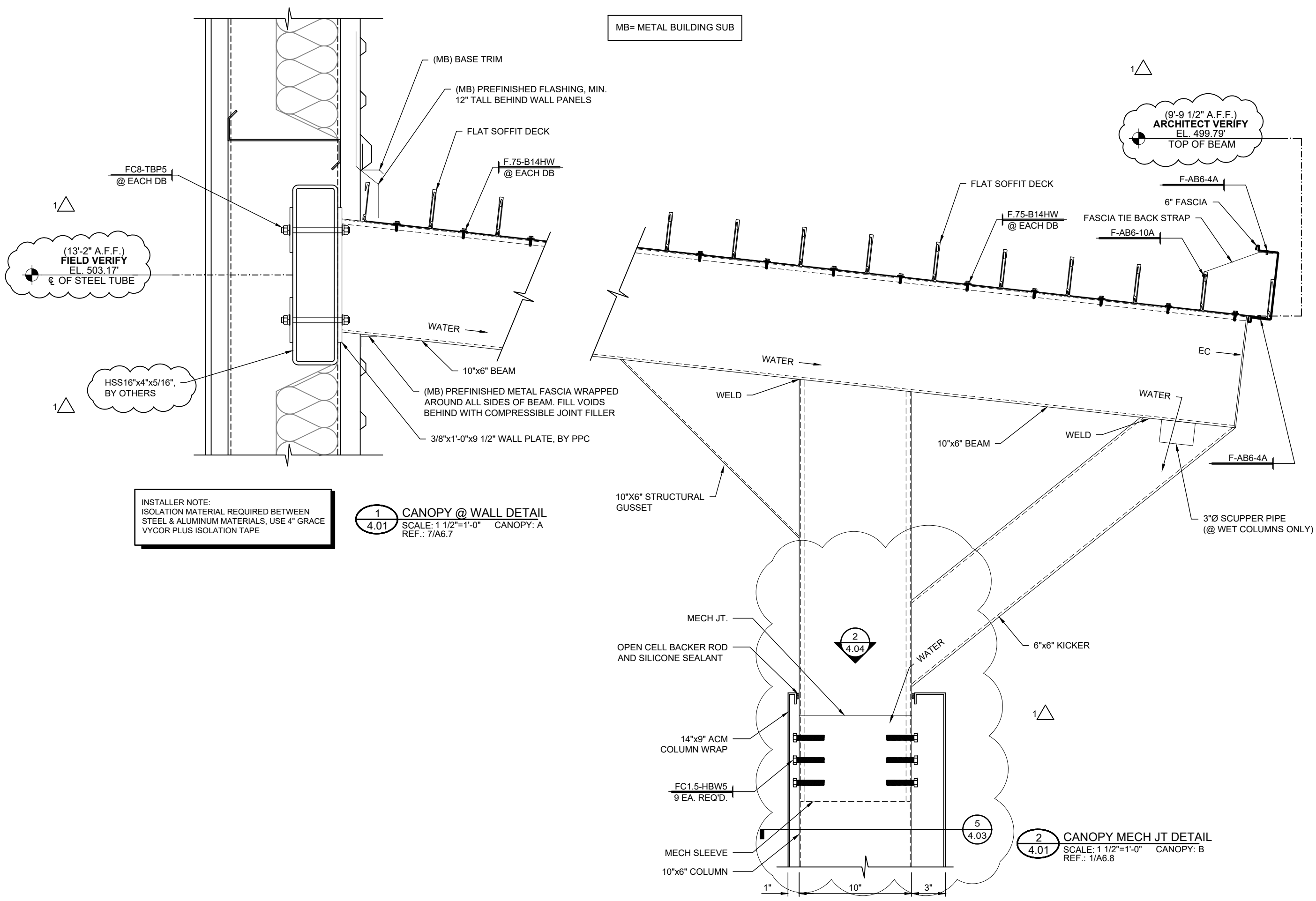

**INSTALLER NOTE:**  
ISOLATION MATERIAL REQUIRED BETWEEN STEEL & ALUMINUM MATERIALS, USE 4" GRACE VYCOR PLUS ISOLATION TAPE

**1**  
4.01  
**CANOPY @ WALL DETAIL**  
SCALE: 1 1/2"=1'-0" CANOPY: A  
REF.: 7/A6.7

**2**  
4.01  
**CANOPY MECH JT DETAIL**  
SCALE: 1 1/2"=1'-0" CANOPY: B  
REF.: 1/A6.8

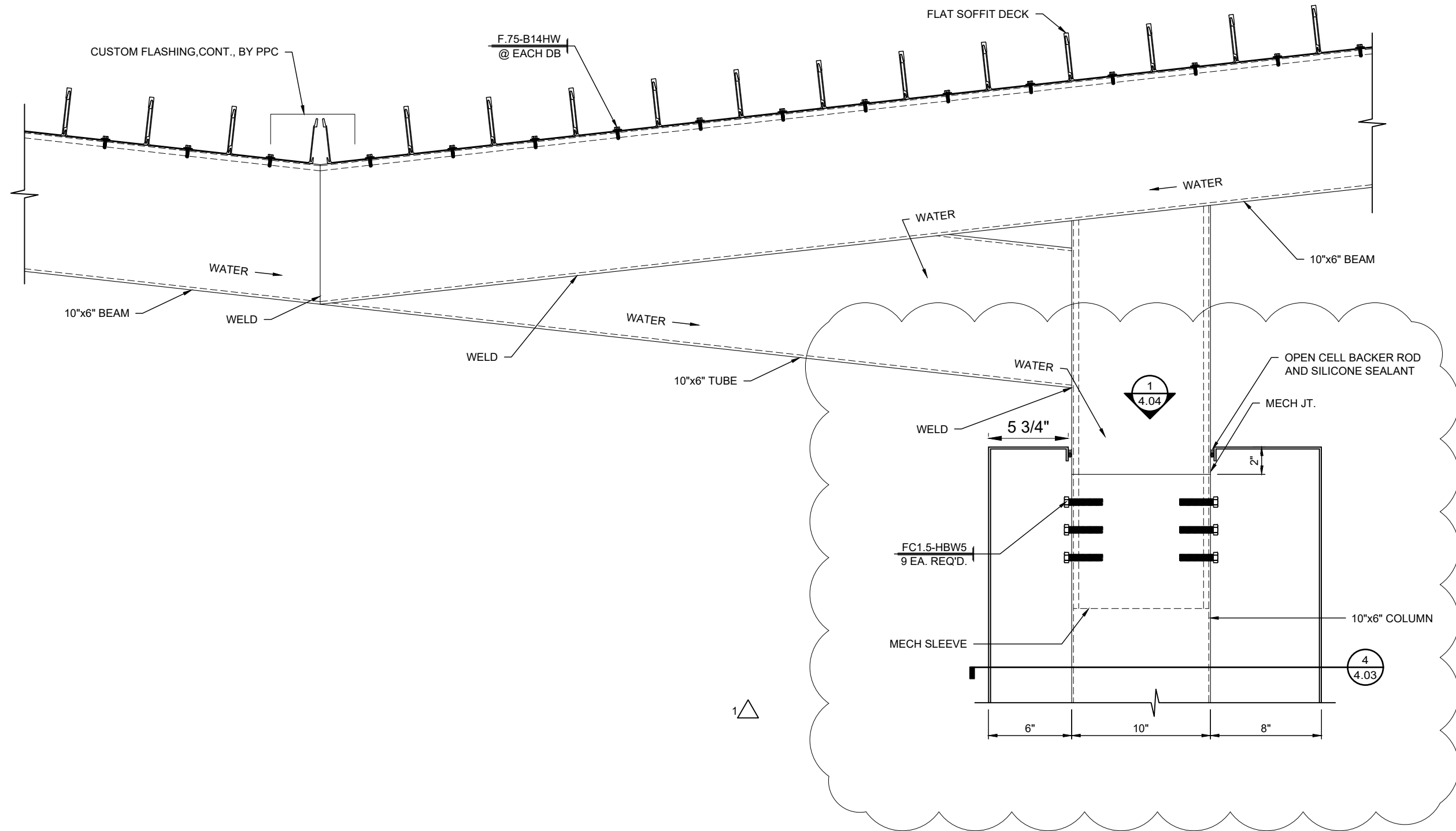

1  
4.02 CANOPY MECH JT DETAIL  
SCALE: 1 1/2"=1'-0" CANOPY: A  
REF.: 5 & 6/A6.7

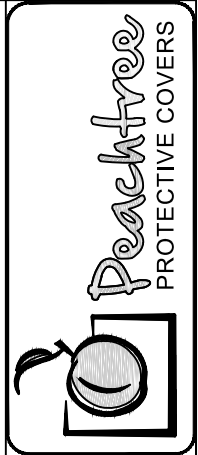

DWG. BY	LKA
SUBJECT	INITIAL FILE & FIELD DWGS
DATE	3/4/16
REV.	1

PROJECT:	GRACE COMMUNITY CHURCH
CUSTOMER:	BELL & ASSOCIATES CONSTRUCTION, LP
ARCHITECT:	RUFUS JOHNSON ASSOCIATES OF CLARKSVILLE, INC.
LOCATION:	CLARKSVILLE, TN

DATE:	11/6/15
DWN. BY:	LKA
CHKD. BY:	RW
DRAWING NO.:	4.02
PPC JOB NO.:	6319

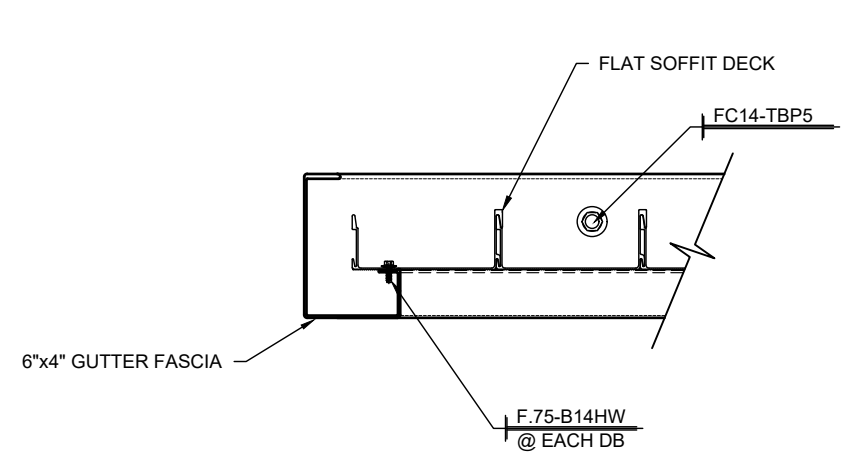

**1** CANOPY SECTION  
4.03 SCALE: 1 1/2"=1'-0" CANOPY: C  
REF.: NONE

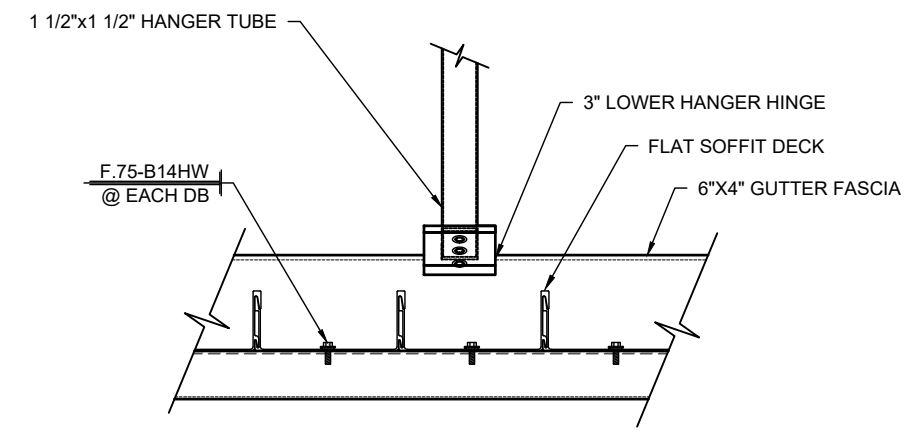

**2** CANOPY SECTION  
4.03 SCALE: 1 1/2"=1'-0" CANOPY: C  
REF.: NONE

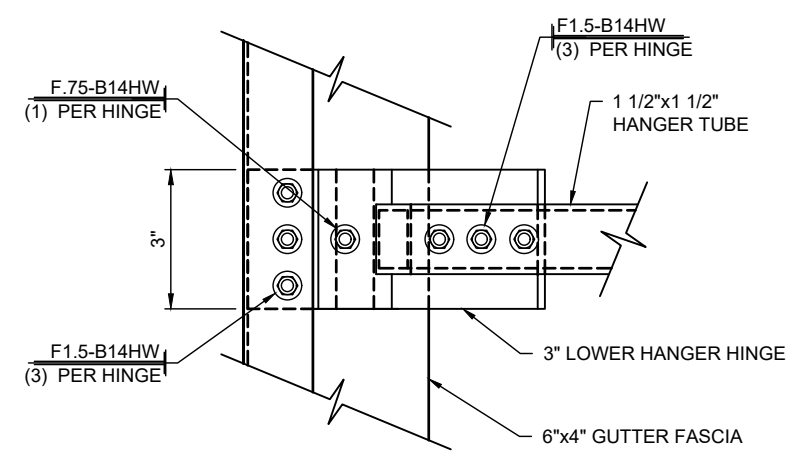

**3** CANOPY SECTION  
4.03 SCALE: 3"=1'-0" CANOPY: C  
REF.: NONE

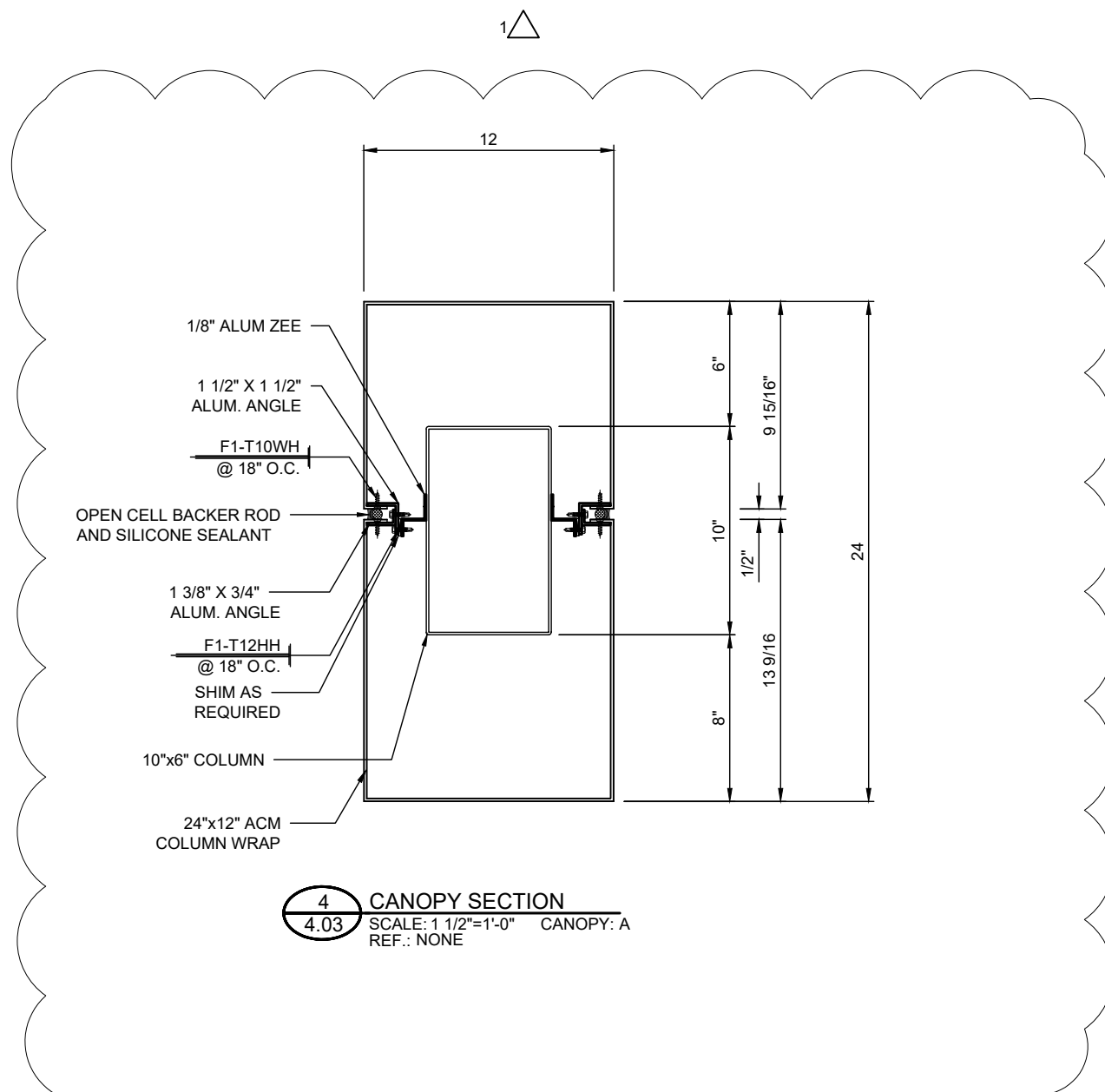

**4** CANOPY SECTION  
4.03 SCALE: 1 1/2"=1'-0" CANOPY: A  
REF.: NONE

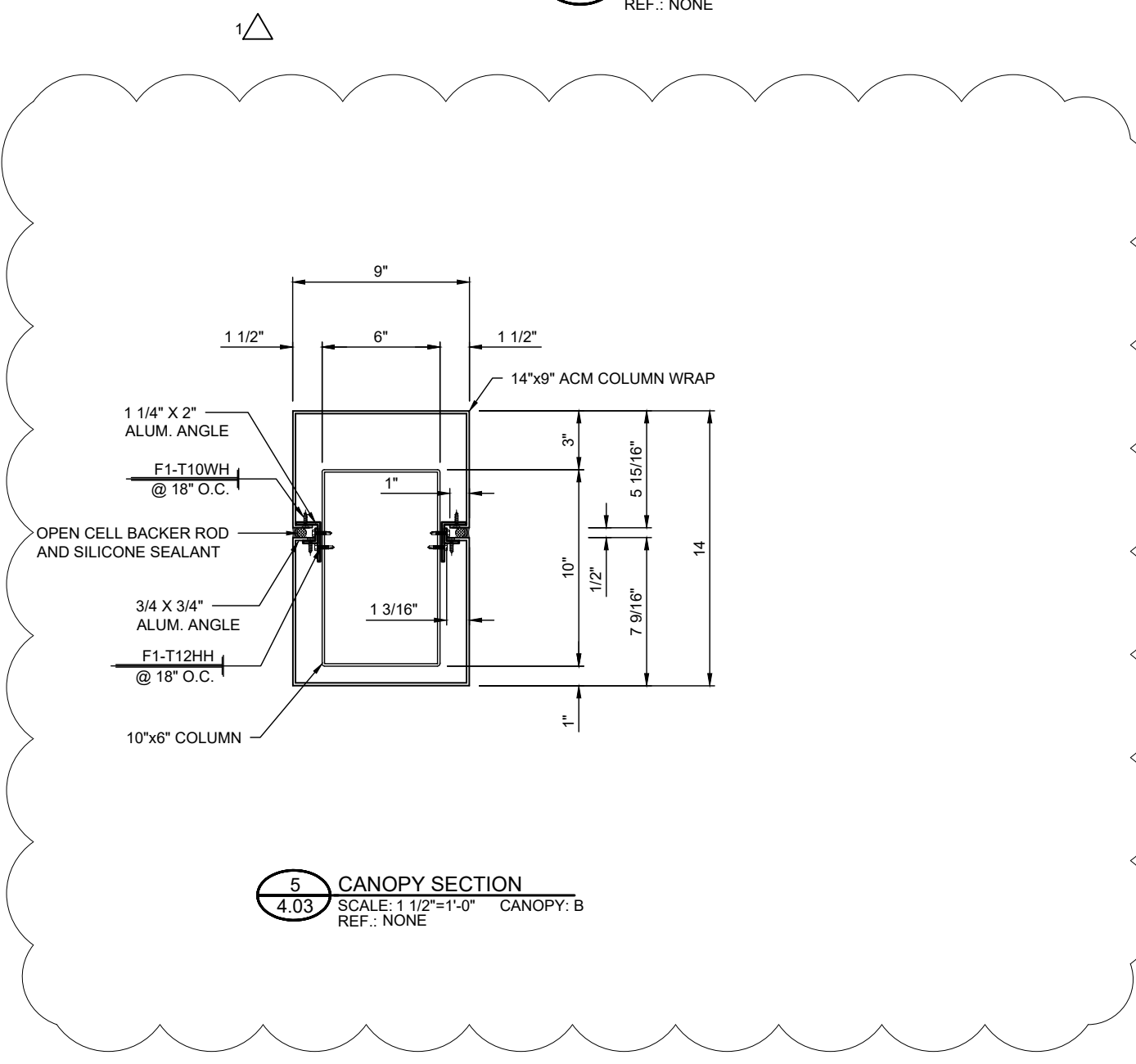

**5** CANOPY SECTION  
4.03 SCALE: 1 1/2"=1'-0" CANOPY: B  
REF.: NONE

DWG. BY	LKA
SUBJECT	INITIAL FILE & FIELD DWGS
DATE	3/4/16
REV.	1

PROJECT	GRACE COMMUNITY CHURCH
CUSTOMER	BELL & ASSOCIATES CONSTRUCTION, LP
ARCHITECT	RUFUS JOHNSON ASSOCIATES OF CLARKSVILLE, INC.
LOCATION	CLARKSVILLE, TN

DATE	11/6/15
DWN. BY	LKA
CHKD. BY	RW
DRAWING NO.	4.03
PPC JOB NO.	6319

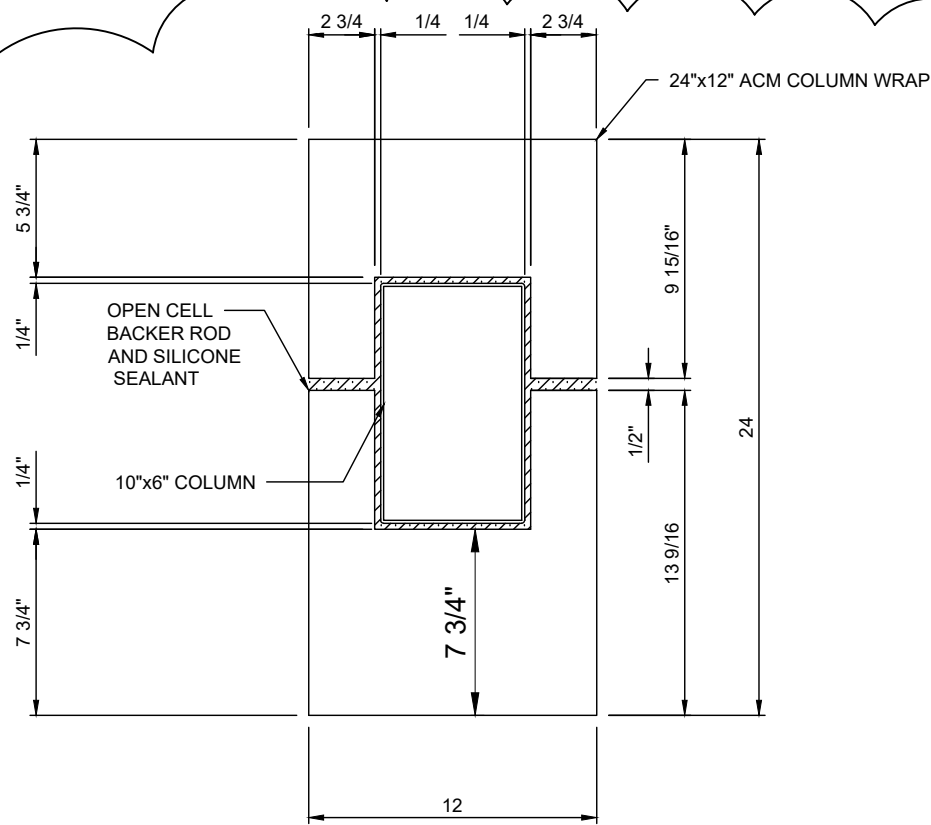

**1** COLUMN WRAP TOP PLAN  
**4.04** SCALE: 1 1/2"=1'-0" CANOPY: A  
 REF.: NONE

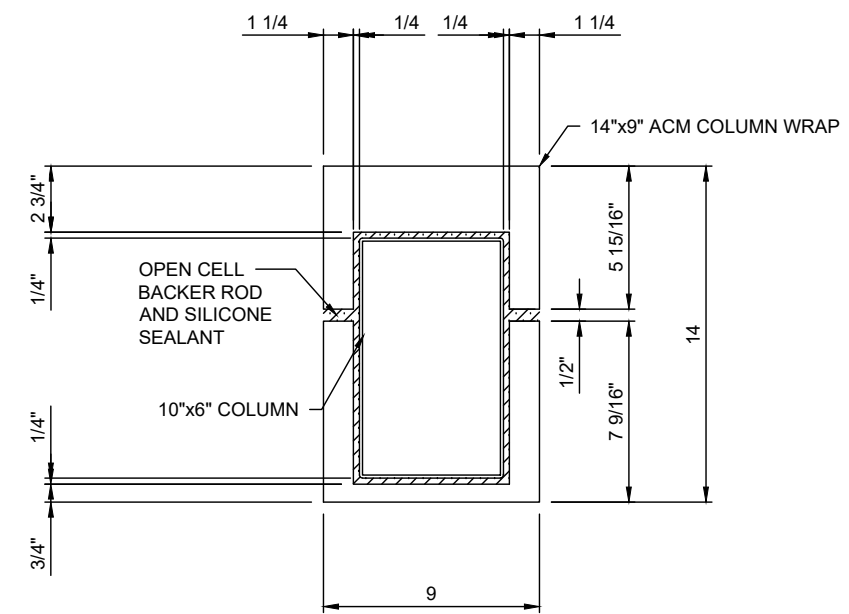

**2** COLUMN WRAP TOP PLAN  
**4.04** SCALE: 1 1/2"=1'-0" CANOPY: B  
 REF.: NONE

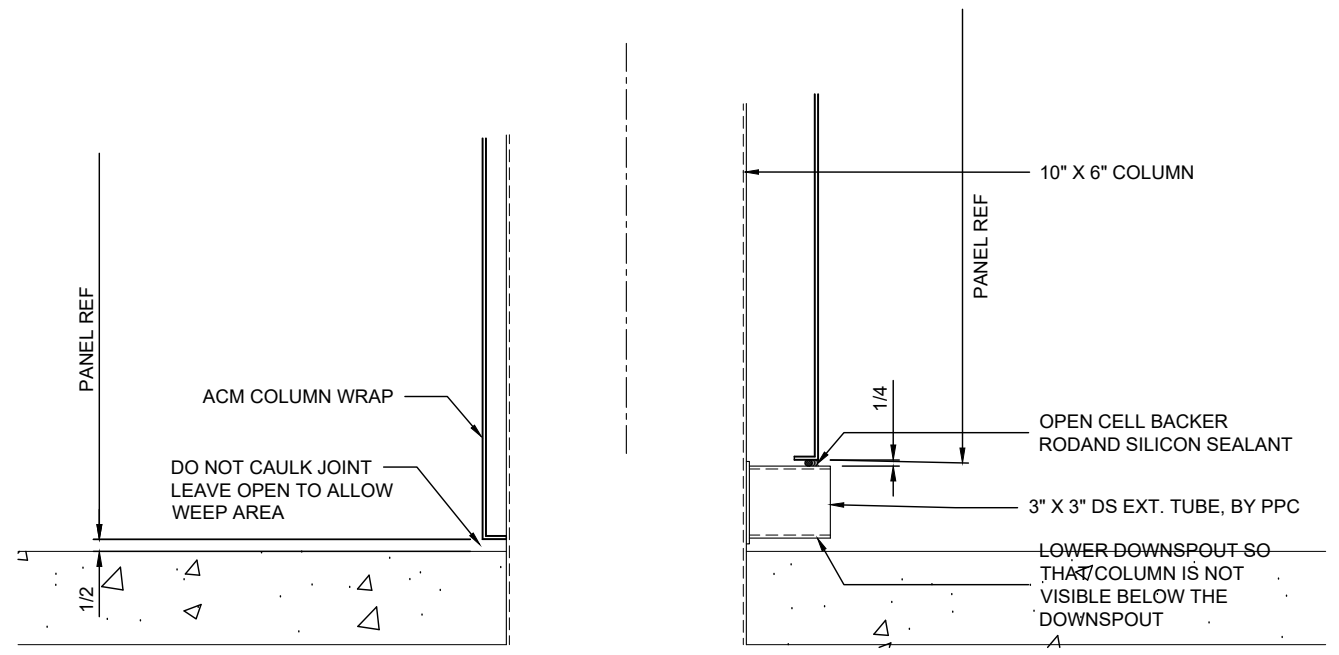

**3** COLUMN DETAIL @ DOWNSPOUT  
**4.04** SCALE: 1 1/2"=1'-0" CANOPY: A  
 REF.: NONE

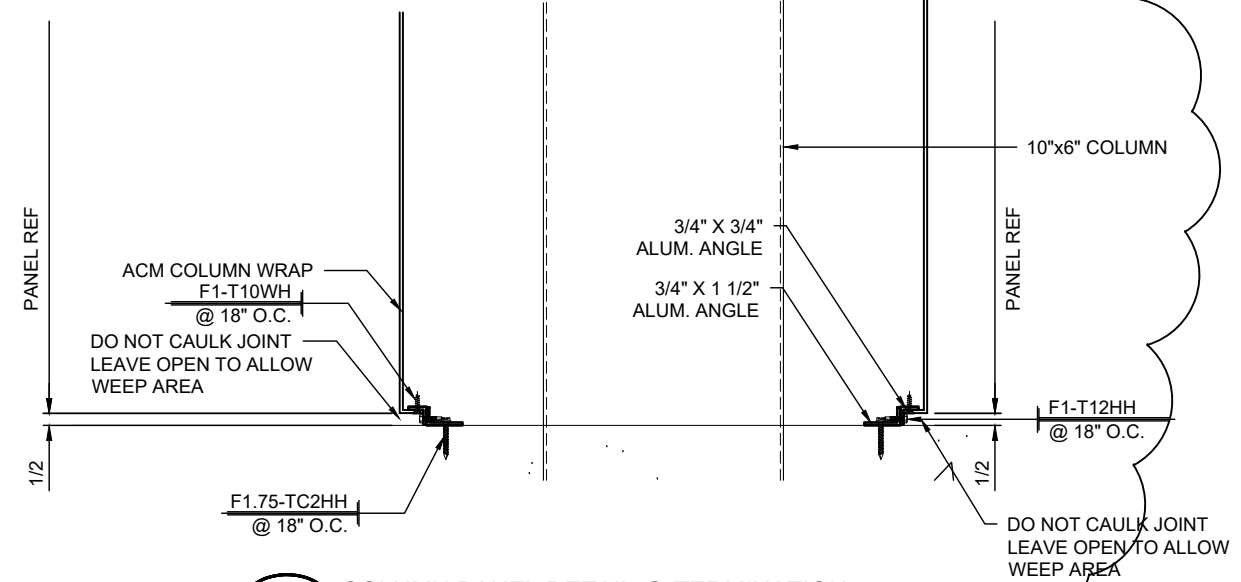

**4** COLUMN PANEL DETAIL @ TERMINATION  
**4.04** SCALE: 1 1/2"=1'-0" CANOPY: B  
 REF.: NONE

REV.	DATE	SUBJECT	DWG. BY
1	3/4/16	INITIAL FILE & FIELD DWGS	LKA

PROJECT:	GRACE COMMUNITY CHURCH
CUSTOMER:	BELL & ASSOCIATES CONSTRUCTION, LP
ARCHITECT:	RUFUS JOHNSON ASSOCIATES OF CLARKSVILLE, INC.
LOCATION:	CLARKSVILLE, TN
DATE:	11/6/15
DWN. BY:	LKA
CHKD. BY:	RW
DRAWING NO.:	4.04
PPC JOB NO.:	6319

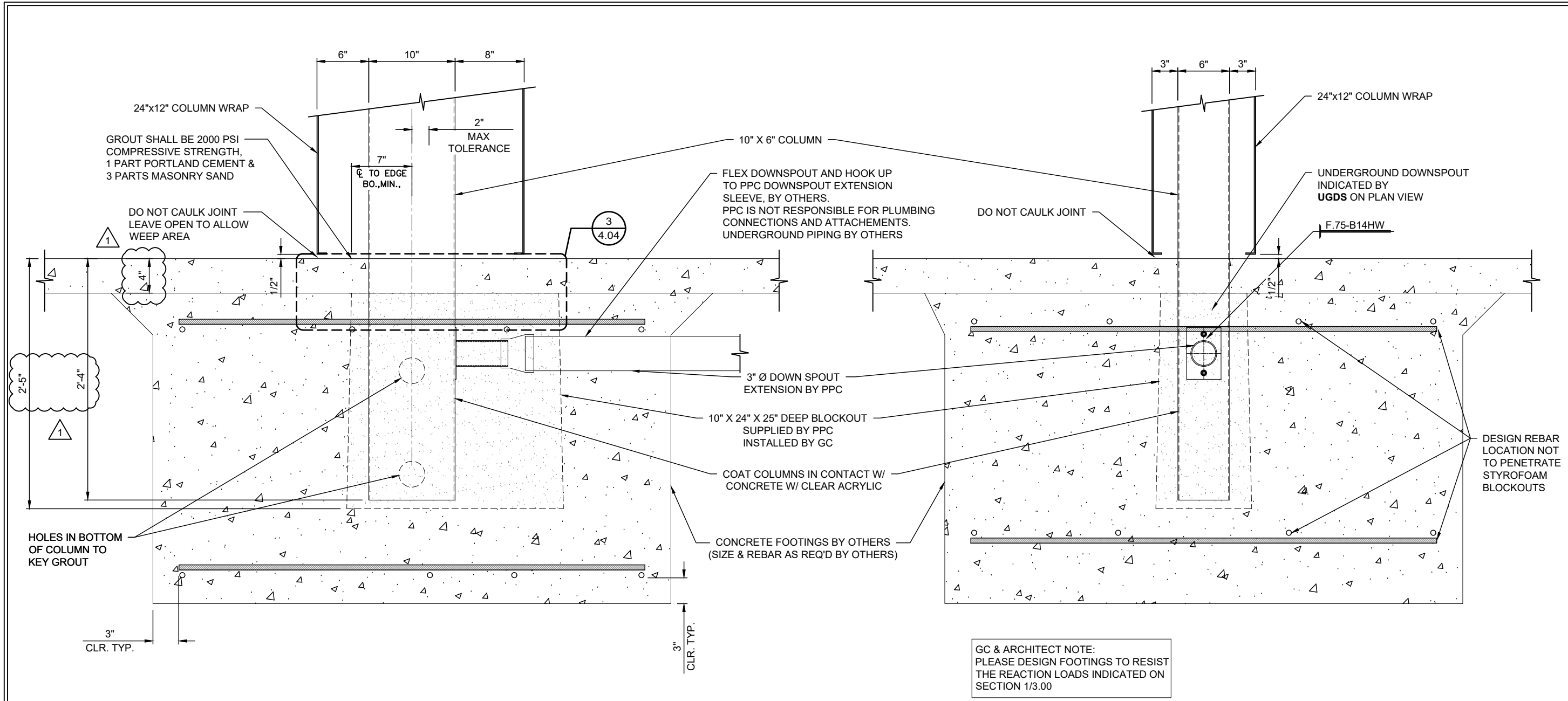

**1** BLOCKOUT DETAIL  
5.00 SCALE: 1"=1'-0" CANOPY: A  
REF.: 4/A6.7

**BLOCKOUT SCHEDULE**

LABEL	DETAIL	BLOCKOUT	CANOPY
B1	1/5.00	10" X 24" X 25"	CANOPY A
B2	1/5.00	14" X 14" X 25"	CANOPY A
B3	1/5.01	14" X 14" X 25"	CANOPY B

DWG. BY	LKA
SUBJECT	INITIAL FILE & FIELD
DATE	3/4/16
REV.	1

PROJECT: GRACE COMMUNITY CHURCH  
 CUSTOMER: BELL & ASSOCIATES CONSTRUCTION, LP  
 ARCHITECT: RUFUS JOHNSON ASSOCIATES OF CLARKSVILLE, INC.  
 LOCATION: CLARKSVILLE, TN

DATE:	11/6/15
DWN. BY:	LKA
CHKD. BY:	RW
DRAWING NO.:	5.00
PPC JOB NO.:	6319

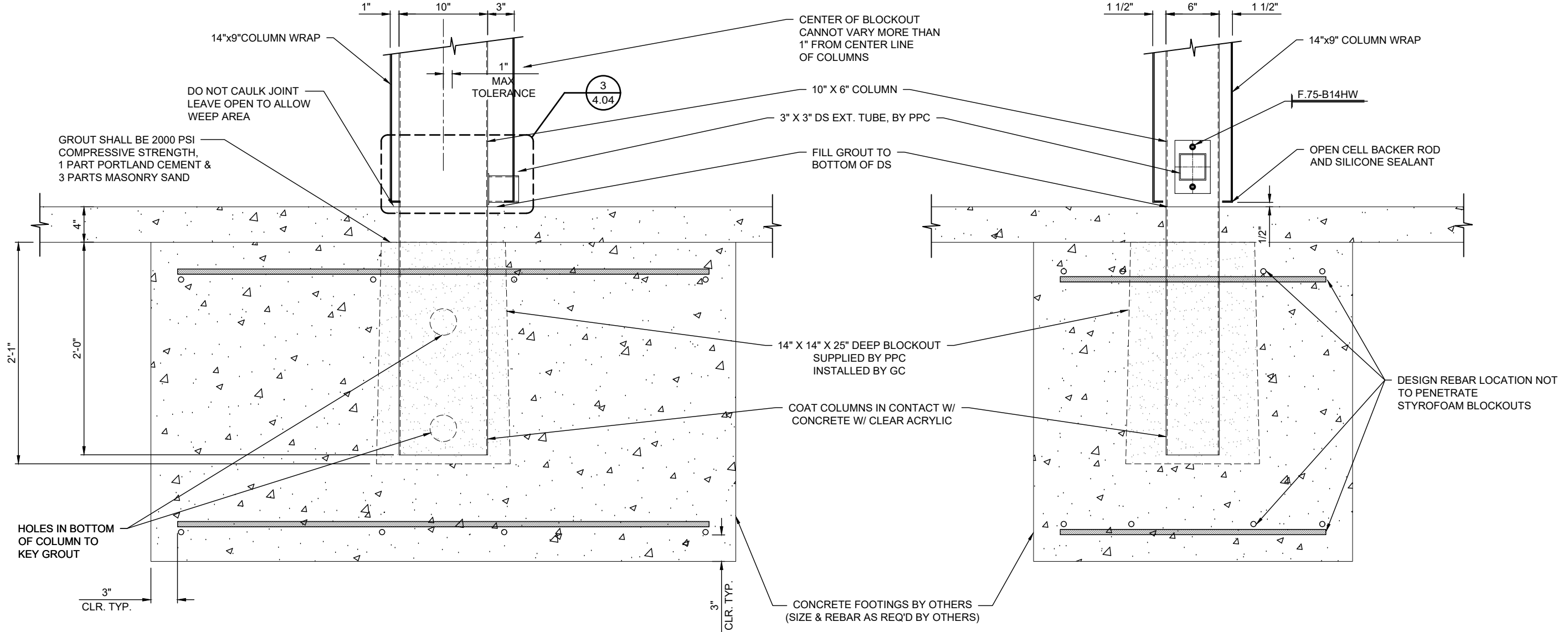

GC & ARCHITECT NOTE:  
PLEASE DESIGN FOOTINGS TO RESIST  
THE REACTION LOADS INDICATED ON  
SECTION 2/3.00

**1**  
**5.01** BLOCKOUT DETAIL  
SCALE: 1"=1'-0" CANOPY: B  
REF.: 1/A6.8

DWG. BY	
SUBJECT	
DATE	
REV.	
PROJECT	GRACE COMMUNITY CHURCH
CUSTOMER	BELL & ASSOCIATES CONSTRUCTION, LP
ARCHITECT	RUFUS JOHNSON ASSOCIATES OF CLARKSVILLE, INC.
LOCATION	CLARKSVILLE, TN
DATE	11/6/15
DWN. BY	LKA
CHKD. BY	RW
DRAWING NO.	5.01
PPC JOB NO.	6319

# FASTENER SCHEDULE

## FASTENER IDENTIFICATION

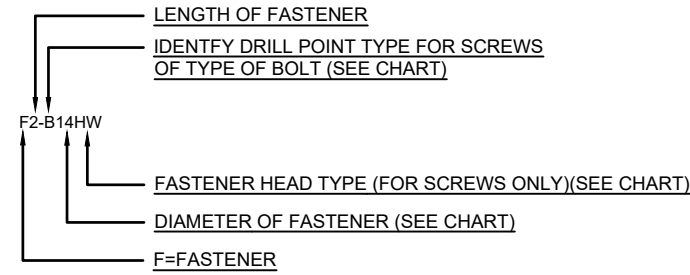

## FASTENER ACCESORIES IDENTIFICATION

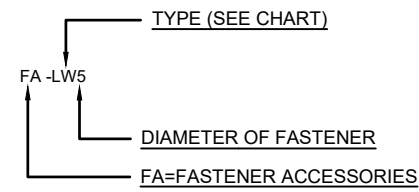

## FASTENER COMBO IDENTIFICATION

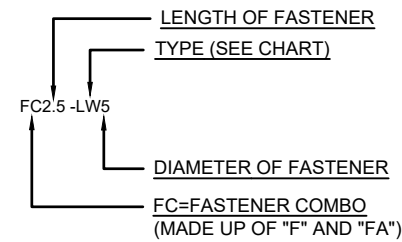

## FASTENER MISC. IDENTIFICATION

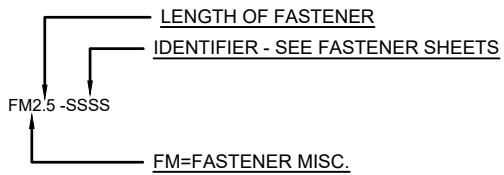

### FASTENER DIAMETER CHART

- 10 = #10
- 12 = #12
- 14 = #14
- 2 = .250" (1/4")
- 3 = .375" (3/8")
- 5 = .500" (1/2")
- 6 = .625" (5/8")
- 7 = .750" (3/4")

### F=FASTENER

- B B POINT
- BB BUTTON HEAD BOLT
- CB COUNTER SUNK BOLT
- EBR EYE BOLT RIGHT HAND THREAD
- EBL LEFT HAND THREAD
- HB HEX HEAD BOLT
- LB LAG BOLT
- SB SHOULDER BOLT
- T TEK
- TC TAPCON
- TR THREADED ROD
- W WOOD SCREW

### FA=FASTENER ACCESSORIES

- AN ACORN NUT
- BW BONDED WASHER
- FW FLAT WASHER
- JN JAM NUT
- IW INTERNAL WASHER
- LS LAG SHIELD
- LW LOCK WASHER
- N NUT
- NS NUTSERT

### FC=FASTENER COMBO

- BBP BACK TO BACK IBP
- CHU CUSTOM HANGER CANOPY UPPER
- CHL CUSTOM HANGER CANOPY LOWER
- EAS EPOXY ANCHOR WITH SCREEN
- EABP EPOXY ANCHOR WITH STANDOFF BASEPLATE
- EASC EPOXY ANCHOR WITH SCREEN & COMP. SLEEVE
- HCU HANGER CANOPY UPPER BRACKET
- IBP INTERNAL BOLT PLATE
- NMJ NEW MECH JOINT
- NS NUTSERT
- OMB OLD MECH. JOINT W/ BUTTON HEAD
- OMC OLD MECH. JOINT W/ COUNTER SUNK
- TBP THRU BOLT WITH BACKER PLATE
- TBPC THRU BOLT WITH BACKER PLATE W/COMP. SLEEVE
- DT DRILL & TAP THREADED ROD
- DTC DRILL & TAP THREADED ROD W/COMP. SLEEVE
- WLH WELDED LOWER HANGER BRACKET

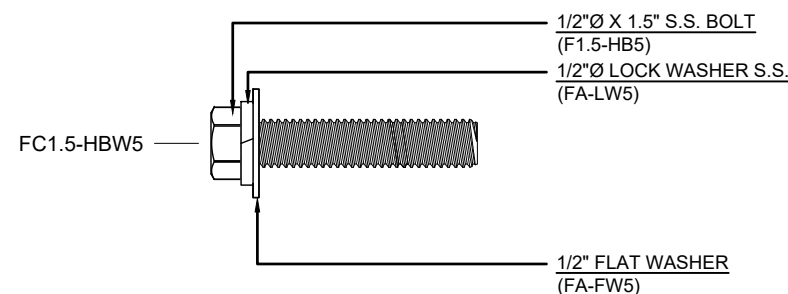
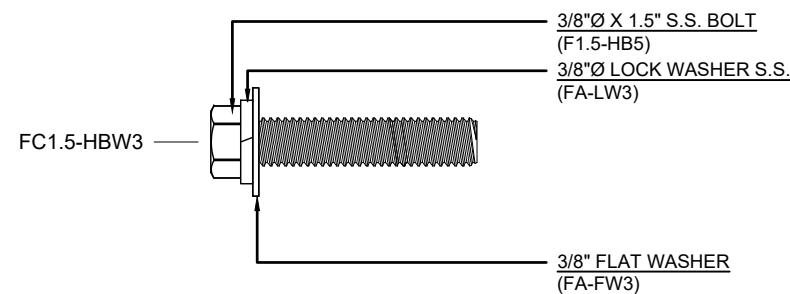
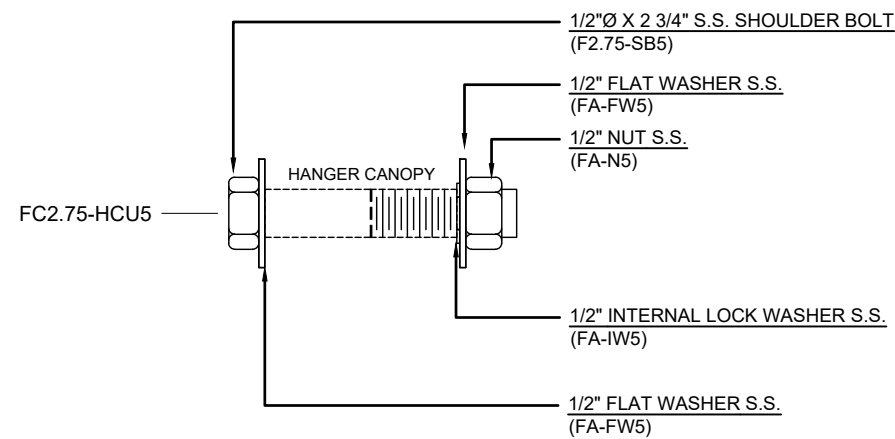
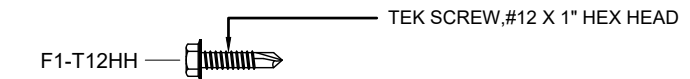
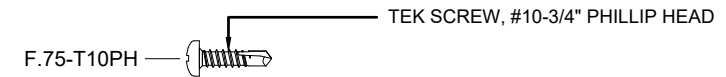
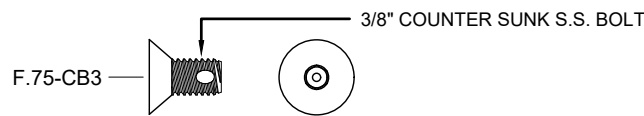
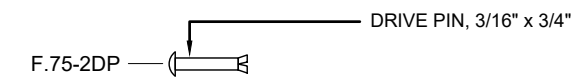
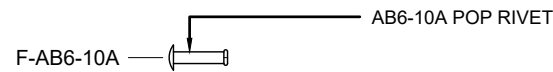
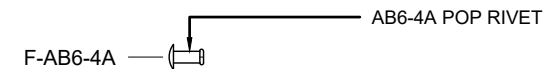

F##-B14HW	
14B S.S FASTENER W/ NEOPRENE WASHER	
F.75-B14HW	3/4" LONG FASTENER
F1.5-B14HW	1 1/2" LONG FASTENER
F2-B14HW	2" LONG FASTENER
F3-B14HW	3" LONG FASTENER
F5-B14HW	5" LONG FASTENER

F##-HB5	
1/2" Ø S.S. HEX HEAD BOLT #13 THREAD	
F2-HB5	2" LONG BOLT
F2.75-HB5	2.75" LONG BOLT
F3.5-HB5	3.5" LONG BOLT

FASTENER ACCESSORIES					
FA-N#		FA-FW#		FA-LW#	
S.S. NUT		S.S. FLAT WASHER		S.S. LOCK WASHER	
FA-N3	3/8" NUT	FA-FW3	3/8" WASHER	FA-LW3	3/8" WASHER
FA-N5	1/2" NUT	FA-FW5	1/2" WASHER	FA-LW5	1/2" WASHER
FA-N6	5/8" NUT	FA-FW6	5/8" WASHER	FA-LW6	5/8" WASHER



DWG. BY	
SUBJECT	
DATE	
REV.	

PROJECT:	GRACE COMMUNITY CHURCH
CUSTOMER:	BELL & ASSOCIATES CONSTRUCTION, LP
ARCHITECT:	RUFUS JOHNSON ASSOCIATES OF CLARKSVILLE, INC.
LOCATION:	CLARKSVILLE, TN
DATE:	11/6/15
DWN. BY:	LKA
CHKD. BY:	RW
DRAWING NO.:	6.00
PPC JOB NO.:	6319

# FC - FASTENER COMBINATION SCHEDULE

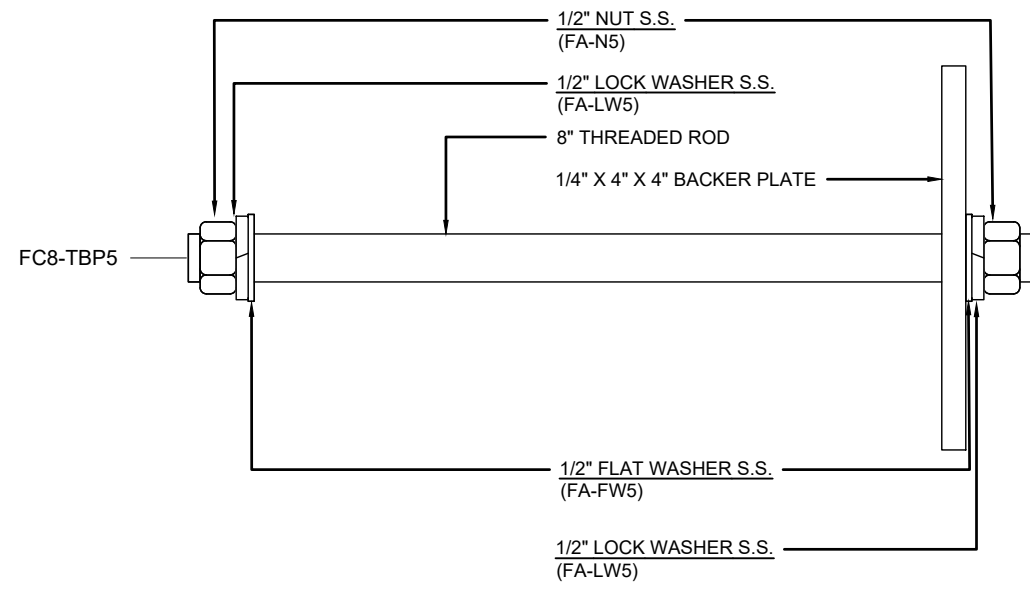
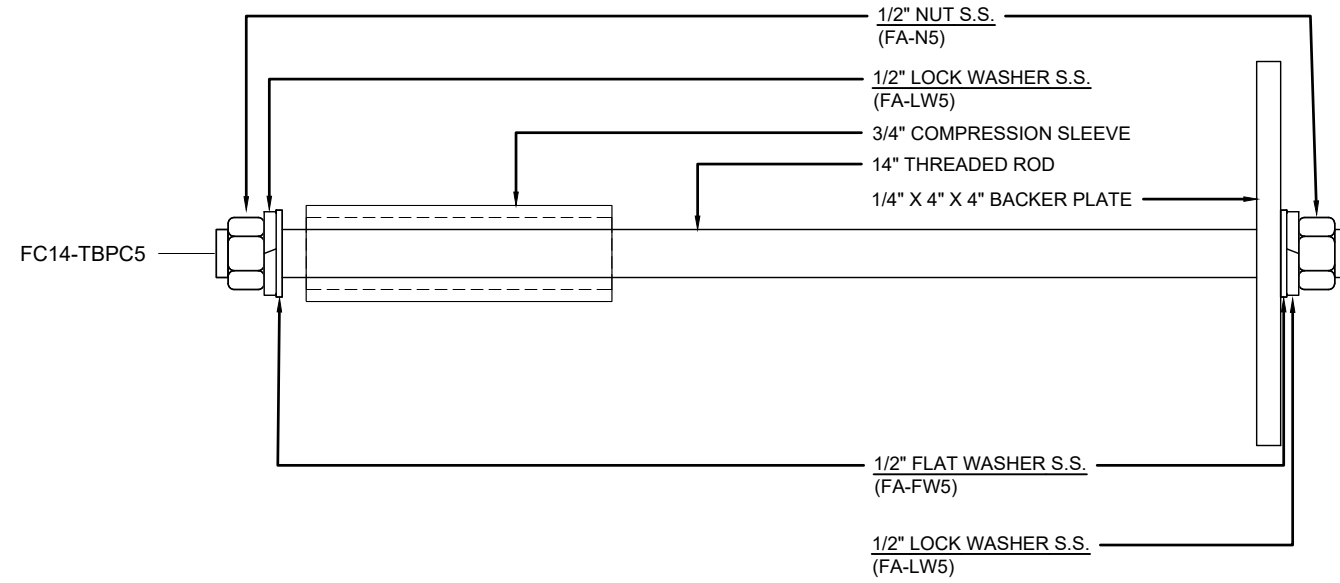
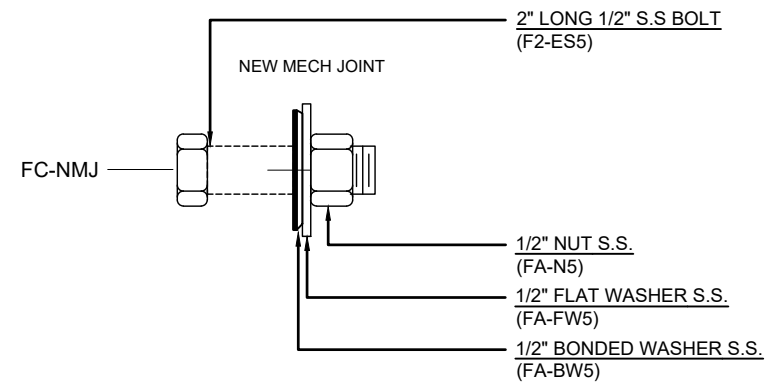
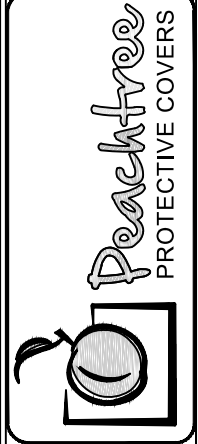

REV.	DATE	SUBJECT	DWG. BY

PROJECT:	GRACE COMMUNITY CHURCH
CUSTOMER:	BELL & ASSOCIATES CONSTRUCTION, LP
ARCHITECT:	RUFUS JOHNSON ASSOCIATES OF CLARKSVILLE, INC.
LOCATION:	CLARKSVILLE, TN
DATE:	11/6/15
DWN. BY:	LKA
CHKD. BY:	RW
DRAWING NO.:	6.01
PPC JOB NO.:	6319